

## **COMMUNITY BASED OPERATION AND MAINTENANCE MANAGEMENT GUIDELINE HAS 8 PARTS**

PART - A INTRODUCTION TO O&M MANAGMENT

PART- B DESCRIPTION OF WATER SOURCES AND TECHNOLOGIES

PART - C TECHNICAL OPERATION AND MAITENANCE  
REQUIRMENTS

PART - D RURAL WATER SUPPLY SCHEMES MANAGMENT

**PART - E RURAL WATER UPPLY SPARE PARTS MANAGMENT**

PART - F M&E AND REPORTING SYSTEM

PART - G WATER SUPPLY SAFETY PLAN

PART - H PREPARATION OF ACTION PLAN



# Community Based Operation and Maintenance Management Manual for Rural Point Water Supply Schemes: Part – E: Spare parts Management

## Draft Manual

### Table of Contents

List of Tables	ii
List of Figures	ii
<b>List of Annexes</b>	<b>iii</b>
<b>5. SPARE PARTS MANAGMENT</b>	<b>1</b>
5.1 Introduction	1
5.1.1 General	1
5.1.2 Defining the Goal	1
5.1.3 Definition	2
5.1.4 Objectives of the guideline	2
5.1.5 Principle and Responsibilities	2
5.1.6 How to use the Guideline	4
5.2 Spare part Outlet Models	5
5.2.1 Spare Part Requirements	5
5.2.1.1 Handpump density	5
5.2.2 Spare Parts Supply and Hand Pump Maintenance System	7
5.2.3 Requirements for Organizations to SP Outlets	7
5.2.4 SP Outlet Models	8
5.2.4.1 No-seed SP model	8
5.2.4.2 Seed SP Provision Model	10
5.2.4.3 Recommended Models	15
5.3 Principles of Planning SP Outlet Allocation	17
5.3.1 Universal Access to SPs	17
5.3.2 Appropriate Distance	17
5.3.3 Accessibility	18
5.3.4 Convenience for Zone Water Offices	19
5.3.5 Selection of Cities/Towns	19
5.4 SP Outlet Allocation Plan	20
5.4.1 Existing SP Outlets	20
5.4.2 Preparation of Action Plan	20
5.4.3 Budget Plan	23
5.5 Procurement and Service Linkages	24
5.5.1 Alternative Spare Parts Supply Model	25
5.5.1.1 Alternative - I: SPs Procurement through Government Channels	25
5.5.1.2 Alternative II: Supply through Privet Sector	26
5.5.1.3 Recommended System for Supply Chain	26
5.6 Steps to Establish a SP outlet	29
5.6.1 Organization to operate a SP outlet is decided	30
5.6.2 MoU is signed by the parties concerned	31
5.6.3 Preparation to open a SP Outlet	34
5.6.4 SP outlet operation training	34
5.7 Operation of a SP Outlet	37

5.7.1	Fundamental Objective and Major Tasks of SP Outlets	37
5.8	Supervision of SP outlets	38
5.8.1	Structure of Supervision	38
5.8.2	Monitoring and Evaluation	39
5.8.3	Record Keeping for Supervision	40
5.9	Roles of various Stakeholders in Spare part Management	41
5.9.1	National Level	41
5.9.2	Regional Level	41
5.9.3	Private sector enterprises	42
5.9.4	Woreda Level	42
<b>Annexes</b>		<b>43</b>

## List of Tables

Table 5-1:	Responsibilities of Stakeholders in Hand Pump Repairs	3
Table 5-2:	How to use the guideline by stakeholders	4
Table 5-3:	Requirements for an Organization to be operating a SP Outlet	8
Table 5-4:	Recommended Models of SP outlets	8
Table 5-5:	Strengths and Weaknesses of No-seed SP Model	9
Table 5-6:	Examples of lists of seed SPs for Afridev and Indian Mark-II SPs	10
Table 5-7:	Price lists of seed SPs for Afridev and Indian Mark-II SPs	12
Table 5-8:	Strengths and Weaknesses of Seed SP Model (TWS)	14
Table 5-9:	Strengths and Weaknesses of Seed SP Model (Water Offices)	15
Table 5-10:	Overall evaluation results of the models and recommended organizations	16
Table 5-11:	Suitability of each model depending on Market Condition	17
Table 5-12:	Major Activities at each Year	20
Table 5-13:	Example of Estimation budget for the next 5 years on SP outlet establishment	24
Table 5-14:	Advantages and Disadvantages of SPS procured through Government	25
Table 5-15:	Advantages and Disadvantages of SPS procured through Private sector	26
Table 5-16:	Necessary Human Resources and Facilities for an Organization to operate a SP outlet	30
Table 5-17:	Parties concerned to sign MOU	31
Table 5-18:	Contents of MOU	31
Table 5-19:	Responsibility of the Parties Concerned	32
Table 5-20:	Potential actions after expiration of MoU	33
Table 5-21:	Subject of SP operation Training	35
Table 5-22:	List of Actions to Promote SP Outlets	36
Table 5-23:	Details of Main Tasks of SP Outlet Operation	37
Table 5-24:	Outline of M & E	39

## List of Figures

Figure 5-1:	Effect of SP Supply Chain Establishment	2
Figure 5-2:	Conditions for HP Maintenance	3
Figure 5-3:	Handpump Maintenance Mechanism	7
Figure 5-4:	: Convenient location though it is not the centre of the area	18
Figure 5-5:	Inconvenient location though it is the centre of the area	18
Figure 5-6:	Inconvenient location though it is a zonal capital	19
Figure 5-7:	Convenient location since it is located in the centre of the zone	19
Figure 5-8:	Phases to establish SP outlets which cover the whole region	20
Figure 5-9:	Action Plan of the 1 <sup>st</sup> year	21
Figure 5-10:	Action Plan of the 2 <sup>nd</sup> year	22
Figure 5-11:	Action Plan of the 3 <sup>rd</sup> year	23



Figure 5-12: Proposed Supply Chain of RWS Scheme Spare parts	27
Figure 5-13: Supply Chain for Rope Pump	28
Figure 5-14: Steps to Establish a SP outlet	29
Figure 5-15: Flow of selecting Organization to operate SP outlet	30
Figure 5-16: Flow of Promotion	36
Figure 5-17: Fundamental Function and Major Tasks of SP Outlets	37
Figure 5-18: Flow of Reporting and Supervision	39

## List of Annexes

Annex A: Format for SP Price Calculation	43
Annex B: Sample of MoU (in case of X zone)	45
Annex C: Basic Concept of the Spare Parts Supply System	48
Annex D: Sample of a Sign Board	49
Annex E: Spare Part Supply System	50
Annex F: Monthly Financial Report (This sheet must be submitted every month.)	51
Annex G: Proposal for Restocking	52



**Community Based Operation and Maintenance Management Manual for Rural Point Water Supply Schemes**

---



## 5. SPARE PARTS MANAGEMENT

### 5.1 Introduction

#### 5.1.1 General

This section is part of the operation and maintenance management, which deals with the spare part management system for rural water supply system.

The spare parts management includes spare parts requirement, their production and supply, how they are going to be distributed to the Woredas and sold to the user communities.

Spare parts management is the backbone of proper maintenance management system in the water supply sector. Water supply schemes have several mechanical and electrical components that wear and tear with time. In the case of hand pumps, there are parts, which are under friction while the water scheme is functioning. These parts will wear within a certain period of time and need to be replaced as specified in the manufacturer's manual and in this procedure. Spring protection has also some parts that wear at a fast rate.

To supply clean and safety water continuously to community, maintenance of water schemes is crucial. Particularly hand pumps (HPs) require replacement of spare parts (SPs) from time to time, because HPs are made of many movable parts and it is unavoidable wearing and breakage of the parts.

Construction of rural water supply schemes and supply of spare parts has hitherto been done mainly by Regional Water Bureau (RWB), Zonal Water Offices (ZWOs), and Woreda Water Offices (WWOs) and Water Sector Partners (NGOs, UN agencies, multilaterals, etc.) and virtually free. This has resulted in a distorted concept that the communities expect all expenses to be covered by someone else and that water services are free.

However, as the number of HPs has been increased, the stock of SP in the water offices has become insufficient, and the situation naturally creates many malfunctioned HPs. The diversified and non-standardized nature of the goods also poses disincentives to stockpile repair parts by traders. Aiming at solving this problem, COWASH has prepared this guideline to implement rural water supply system spare part management for point water supplies.

The WASH implementation Framework for the Country has been launched and aims at an accelerated growth in coverage as one-WaSH implementation system. This is a welcome step to avert the existing crucial problems; but the Funds for O&M must be there and a better methodology of achieving the contents of the plan needs to be in place. This Study therefore aims at virtually creating a commercial Supply Chains from one dominated by the Public Sector and the Donor community. Consequently, it appears imperative that supply chains for WASHCOs will need to be a Public-Private partnership.

#### 5.1.2 Defining the Goal

What constitutes an *effective and sustainable supply chain*? The overall goal is to ensure that spare parts are:

- Available - i.e. the required components are in stock or can be rapidly delivered;

- Accessible - i.e. WASHCOs are aware of where to find spares outlets and the nearest of these is within easy travelling distance;
- Affordable - i.e. priced within the means of the target communities; and
- Appropriate - i.e. of correct specification and good quality.

In order to ensure that these requirements are met, there must be a sustainable chain of incentives from the manufacturer to the eventual WASHCOs.

### 5.1.3 Definition

In the context of this study, Supply Chains is understood to mean the entire process that includes planning, budgeting, specifying, tendering, delivery, procurement, production and distribution of hardware for new installation and sustainable running of existing water supply schemes involving all the stages from raw material to final production of goods.

### 5.1.4 Objectives of the guideline

The immediate objective of the guideline is to provide a plan for establishing SP outlets which cover the four regions and present manuals which explain how to establish SP outlets and make them operational. If SP outlets are established and sustainably operated, availability of SP will be ensured in their surrounding areas. It will contribute to smooth maintenance of HPs, shortening HPs' down time, and continuously functional HPs. This will ultimately prevent the decrease of water supply coverage ratio. These expected effects from SP outlet establishment are shown in the following figure.

Figure 5-1: Effect of SP Supply Chain Establishment

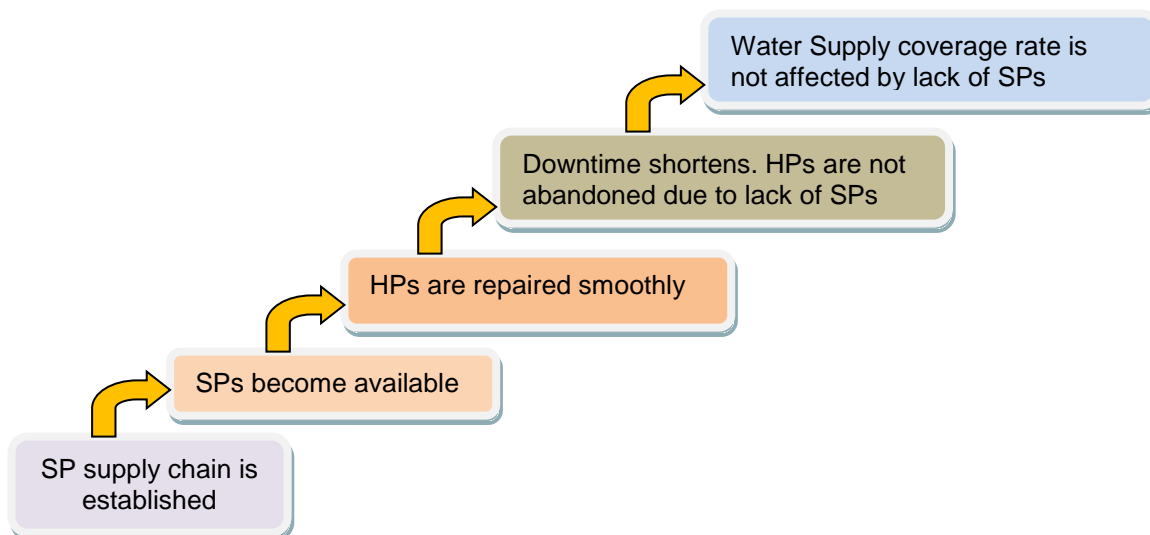

### 5.1.5 Principle and Responsibilities

It is a policy of Regional Water Bureaus' that WASHCOs bear the primary responsibility to purchase SPs for repairing their HPs, though there are some exceptional ceases<sup>1</sup>. However, there was no as such functional shop dealing SPs in rural areas of the regions as a result many WASHCOs do not have an access to SP shops. Therefore, this guideline

<sup>1</sup> Water offices should provide a WASHCO with free SPs when the area is suffered from serious natural disaster or the WASHCO does not have sufficient savings in the early period of its establishment.



primarily discusses the SP issue including establishment, operation, and supervision of SP outlets. Apart from SPs, there are two more conditions to be fulfilled for repairing HPs.

- 1) One of the two conditions is the technical issue. HP repairers including a staff of water offices or NGOs, artisan, a trained member of a WASHCO should be available near to WASHCOs, and they should have skills and tools necessary to repair HPs.
- 2) Another condition is the community issue. WASHCOs should have the sufficient amount of savings to purchase SPs whenever they need. Including SP these three issues are indispensable conditions for HP repair. In other word, only the establishment of SP outlet is not sufficient for sustainable maintenance of HPs. The three issues must be addressed simultaneously as shown in Figure 5.2.

**Figure 5-2: Conditions for HP Maintenance**

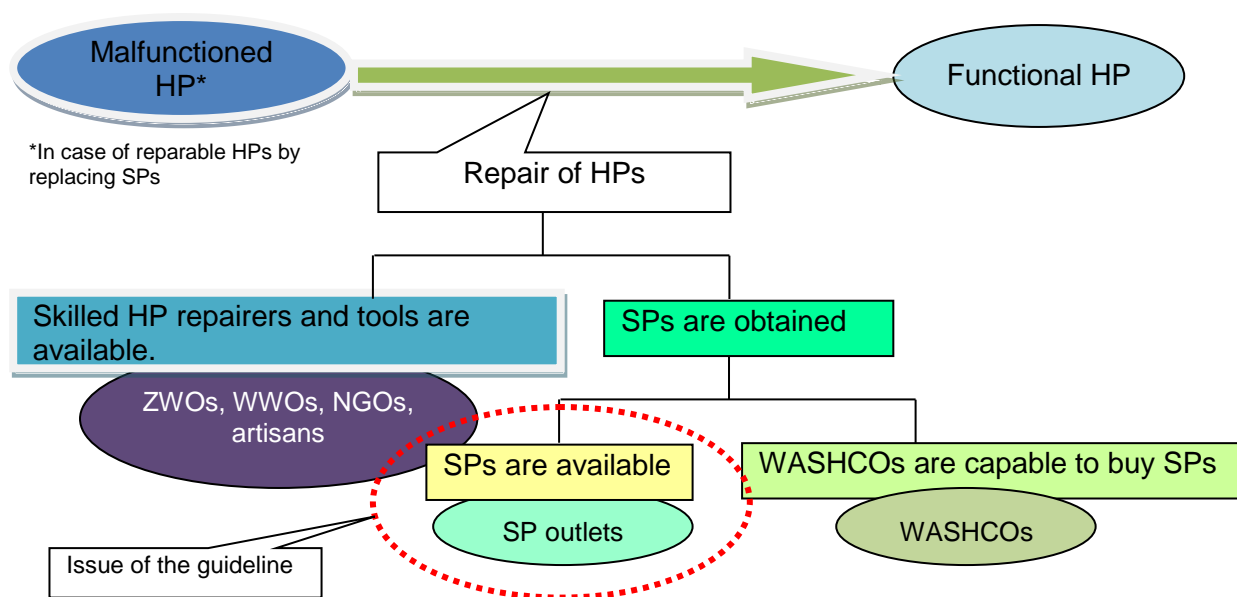

In order to fulfil the three requirements for smooth HP repair, stakeholders such as Water Bureau’s, Zone Water Offices, Woreda Water Offices, WASHCOs, SP outlets, etc. should perform their own responsibility as summarized in Table 5.1.

**Table 5-1: Responsibilities of Stakeholders in Hand Pump Repairs**

No.	Stakeholders	Responsibility
1	Regional Water Bureaus	<ul style="list-style-type: none"> <li>▪ Strengthen Zone Water Offices to fulfill their responsibility</li> <li>▪ Repair a water scheme if it is beyond the capacity of a ZWOs</li> <li>▪ Provide skills, knowledge, facilities to SP outlets to fulfill their responsibility</li> <li>▪ Resource mobilization to perform its responsibility</li> </ul>
2	Zone Water Offices	<ul style="list-style-type: none"> <li>▪ Strengthen WWOs to fulfil their responsibility</li> <li>▪ Repair a water scheme if it is beyond the capacity of a WWO</li> </ul>

		<ul style="list-style-type: none"> <li>▪ Directly supervise the SP outlet to make it functional</li> <li>▪ Resource mobilization to perform its responsibility</li> </ul>
3	Woreda Water Offices	<ul style="list-style-type: none"> <li>▪ Strengthen WASHCOs to fulfil their responsibility</li> <li>▪ Repair a water scheme if it is beyond the capacity of a WASHCO</li> <li>▪ Resource mobilization to perform its responsibility</li> </ul>
4	WASHCOs	<ul style="list-style-type: none"> <li>▪ Collect water tariff to raise money and buy SPs when necessary</li> <li>▪ Conduct preventive maintenance</li> </ul>
5	Local administration	<ul style="list-style-type: none"> <li>▪ Resource allocation</li> </ul>
6	Donor/ NGO	<ul style="list-style-type: none"> <li>▪ Repair a water scheme if it is beyond the capacity of a WASHCO</li> <li>▪ Establish a SP outlet</li> </ul>
7	SP outlets/SP shops	<ul style="list-style-type: none"> <li>▪ Make SPs always available</li> </ul>
8	Local artisans	<ul style="list-style-type: none"> <li>▪ Repair a water scheme with charges</li> </ul>

### 5.1.6 How to use the Guideline

As mentioned in the previous section, this is a comprehensive guideline which includes the SP outlet models, method to prepare the SP outlet allocation plan, established plan, and operation manuals. Therefore, it is expected that the guideline will be utilized, referred, and applied by various stakeholders such as RWBs, ZWOs, WWOs, organizations to be operating SP outlets, donor/NGOs, MoWE Table 5.2 summarizes how to use the guideline by stakeholders.

RWB and organizations to be operating SP outlets are most important stakeholders among them. RWB is the only one stakeholder which can systematically plan and establish more SP outlets to cover the entire region by SP supply network. Organizations to be operating SP outlets are also important users of the guideline. SP outlets may not be functional and sustainable unless they are operated in accordance with the guideline. As many of SP outlets are to be operated by public organizations including water offices and TWS, the operation must be transparent and accountable. Specifically, it is important that precise record keeping on stock and sales and appropriate cash management in line with the guideline.

**Table 5-2: How to use the guideline by stakeholders**

Stakeholders	Responsibility/ Expected actions	Relevant part of the guideline
MoWE	<ul style="list-style-type: none"> <li>▪ Application of the guideline</li> </ul>	Whole guideline
Regional Water Bureaus	<ul style="list-style-type: none"> <li>▪ Planning of SP outlet allocation</li> <li>▪ Facilitation of application of the guideline by MoWE, donor, NGOs,</li> </ul>	Whole the guideline

Stakeholders	Responsibility/ Expected actions	Relevant part of the guideline
	<ul style="list-style-type: none"> <li>▪ Training</li> <li>▪ Supervision of ZWOs and SP outlets</li> <li>▪ Promotion</li> </ul>	
<b>Zone Water Offices</b>	<ul style="list-style-type: none"> <li>▪ Direct supervision of SP outlets in the zone</li> </ul>	Part C Operation Manuals
<b>Organizations to be operating their SP outlets</b>	<ul style="list-style-type: none"> <li>▪ Operation of its SP outlet</li> </ul>	Part C Operation Manuals
<b>Donors/ NGOs</b>	<ul style="list-style-type: none"> <li>▪ Application of the SP outlet model and operation manuals</li> </ul>	Part 1 SP outlet Models Part 3 Operation Manuals

## 5.2 Spare part Outlet Models

The section demonstrates the basic spare parts (SPs) supply model through SP outlets and recommended SP outlet models. Each recommended model is described in details including its strengths and weaknesses, and consequently suitable market environment to the model. In addition, SP outlet models, which are not appropriate, are also shown based on Consultant's assessment report.

### 5.2.1 Spare Part Requirements

The WASHCOs need to know how much their water supply will cost to run and this is determined partly by the demand for spare parts. Estimates may be based on previous experience, or on manufacturers' guidance.

The following rural water construction works will be undertaken in the period.

- 4,255 deep wells
- 9,329 shallow wells
- 27,338 hand-dug wells
- 18,908 spring development
- 223 Sub-surface dams
- 10,761 Ponds, cisterns, ground catchments will be provided for livestock watering.

The total hand pump requirements in the 15-year period would be all of the hand-dug wells and an estimated 25% of the shallow drilled wells.

This amounts to  $27,338 + .25 (9,329) = 29,670 \sim 30,000$  hand pump systems

Average annual requirements, would be 2,000 units, i.e. 40 units per week

#### 5.2.1.1 Handpump density

In order to test the commercial viability of spare parts supply at the user level, one approach is to establish the density of pumps required to produce enough demand to generate sufficient turnover of spares and sufficient profit for the retailer. The minimum density required to fulfill this is defined as the Handpump Density Breakpoint (HDB). We can estimate the HDB by using a very crude method, as follows:

1. There are “N” hand pumps in a given area, and “t” is the average time period between subsequent spare parts required for any given hand pump. The number of parts, n, required from the supplier/local manufacturer/retailer per year is therefore given by:

$$n = \frac{N}{t(\text{years})}$$

2. If the average profit per spare part sold is “p<sub>a</sub>”, the annual profit, P, generated from the sale of spare parts will be given by:

$$P = P_a \times n$$

*Approximation 1:* Based on all parts weighted for frequency of breakdown the average profit per part is approximately: P<sub>a</sub> = 15.00 Birr.

$$P = 15 \times n = \frac{N}{t} \Rightarrow N = 15Pt$$

3. If P<sub>min</sub> is the minimum annual profit (in Birr) required by the supplier for commercial viability, then the minimum number of handpumps, N<sub>min</sub>, required within a given radius of access, will be:

$$N_{\min} = P_{\min} \times t$$

4. Radius of access, R<sub>a</sub>, is defined as the average of the maximum distances from the retailer to potential customers in all directions, and determines the area realistically served. This will be heavily influenced by transportation links, topography, geographical and political boundaries etc.
5. The Handpump Density Breakpoint (pumps/km<sup>2</sup>) is given by:

$$HDB = P_{\min} \times \frac{t}{\pi R_a^2}$$

### Box 5.1. Calculating Handpump Density Breakpoint

For an India Mark II pump, average time between the spare parts required t = 2 Years, and the radius of access, R<sub>a</sub> = 50km.

Based on interviews with retailers, an annual profit of at least Birr 1,000 is required to make spares supply commercially worthwhile. This is a conservative figure, based on minimum figures quoted and P<sub>min</sub> is likely to be higher in most cases.

$$HDB = 1,000 \times 2 / (3.14 \times 50^2) = 0.254 \text{ pumps / km}^2$$

$$N_{\min} = P_{\min} \times t = 1,000 \times 2 = 2,000$$

i.e. 2,000 pumps within 50 km of outlet

### 5.2.2 Spare Parts Supply and Hand Pump Maintenance System

It is necessary to establish SP outlets at accessible areas for WASHCOs to buy SPs. By establishing SP outlets in zones or Woredas, SPs can be supplied to WASHCOs in Kebeles. In this way, SP supply chain from the regional to Kebele levels will be established as shown in Figure 5-3. These SP outlets must supply SPs sustainably. Specifically they sell SPs, keep the sales, and restock SPs continuously. It is same as creation of SP revolving fund. Various kinds of entities can operate a SP outlet, and recommended organizations are discussed in subsequent sections. For effective use of SP outlets in appropriate HP maintenance, WASHCOs should collect water tariff, and skilled HP area mechanics with necessary tools must exist around WASHCOs.

**Figure 5-3: Handpump Maintenance Mechanism**

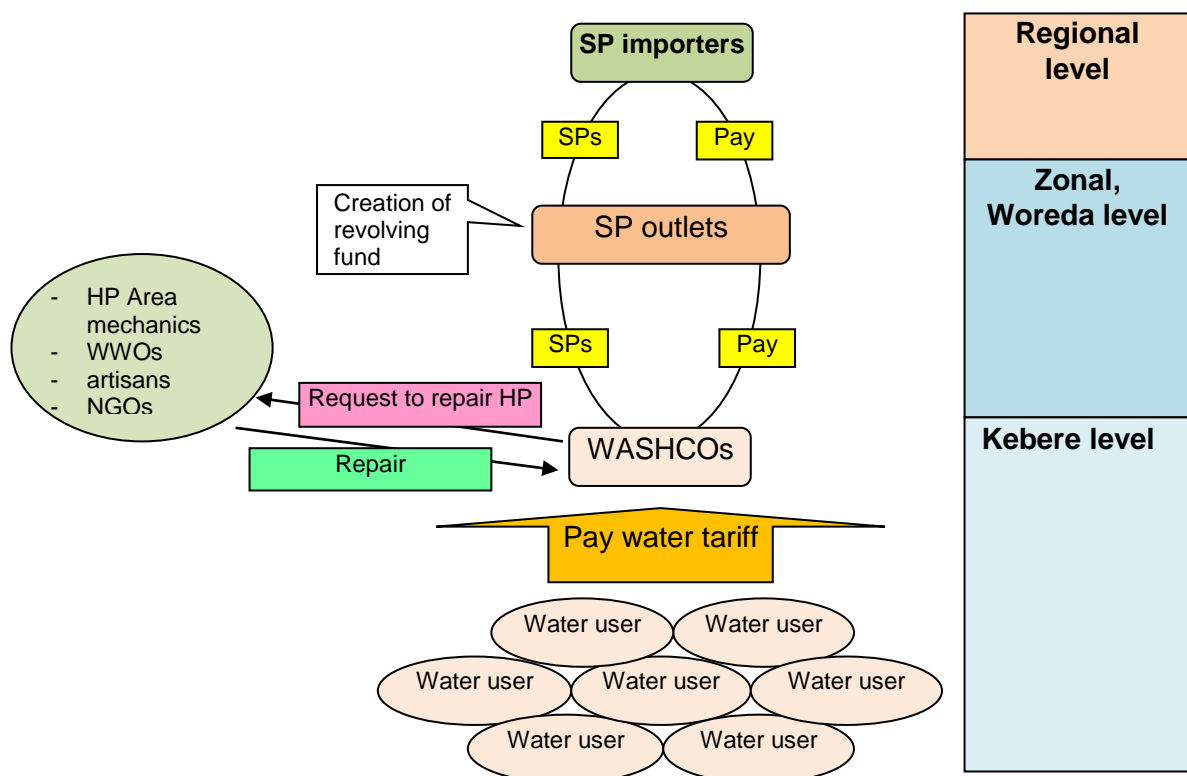

### 5.2.3 Requirements for Organizations to SP Outlets

In order to establish an SP outlet, there must be an organization which operates its SP outlet. In selecting such organization, the following requirements for the organization specified according to its function should be considered first. The function of a SP outlet is basically to store and sell SPs. Existence of an appropriate storeroom and always available quality staff are the two major requirements as shown in Table 5.3. Moreover, in order to meet the two requirements, an organization must be a currently existing organization which carries out its own business either public or private. It should be avoided to create a new organization such as a cooperative so as to exclusively operate a SP outlet. The detailed reasons are described in section 5.2.4 Other Models tested.

Table 5-3: Requirements for an Organization to be operating a SP Outlet

Items	Descriptions
<b>Facilities</b>	▪ Storeroom with lockable system to keep SPs (larger than 3m x 4m)
<b>Human resources</b>	▪ Permanent staff of the organization who can spare a time to operate a SP outlet every working day ▪ The staff should be capable enough to operate a SP outlet.
<b>Establishment of Organization</b>	▪ An organization should not be a newly formed for operation of SP outlet but a well established existing entity.

## 5.2.4 SP Outlet Models

There are in fact multiple candidate organizations which fulfill the requirements in Table 5.3

In the private sector, machine & equipment shops, building material shops, daily consumable goods shops, and cooperatives may be eligible. While, in the public sector, Water Offices including all ZWOs and some of WWOs can be candidate organization.

These potential organizations can be classified into two groups depending on who prepare the initial stock of SPs as seed SPs. If an organization in the private sector establishes its SP outlet, seed SPs must be purchased by their own expenses. This case is regarded as the no-seed SP model. On the other hand, Regional Water Bureaus provide seed SPs to Zone and Woreda Water Offices if they open their SP outlets. This should be acknowledged as the seed SP provision model. The models, candidate organizations and their types are summarized in Table 5.4. Characteristics of each model and organization for SP outlets are shown in the following two sections.

Table 5-4: Recommended Models of SP outlets

Models	No seed SP model	Seed SP provision model	
<b>Types of candidate organizations</b>	Private Entities	Public Enterprise	Government organizations
<b>Candidate organizations</b>	Machine & equipment shops, building material shops, daily consumable goods shops, and cooperatives	TWS	Zone and Woreda Water Offices

### 5.2.4.1 No-seed SP model

In this model, it is expected that a private entity prepares initial stock of SPs by its own expenses to start selling SPs. This model requires minimal government support to open and operate a SP outlet. First of all, the largest expense in establishing SP outlets is the initial stock of SPs, but the stock will be purchased by a private entity to be operating its SP outlet, because it is not rationale that Regional Water Bureaus provides free seed SPs to a specific private entity. The first task of RWBs in this model is to convince a candidate private entity that the demand of SPs exists. Such demand may not be observable, because WASHCOs always contact with Water Offices when they need SPs. RWBs should estimate the size of demand by referring the number of HPs and explain to the private entity as examples of calculation above.

Second, time and energy to train and supervise the staff of a SP outlet is a big burden for RWB's, but the burden will be dramatically reduced. Because, the staff's of a private entity, building material shops in many cases are well accustomed with commercial activities such as selling, accounting, and restocking. Minimal training and guidance are sufficient for them to deal SPs in their shops.

Main task of RWB's in this model is the promotion of the SP outlet to concerning ZWOs, WWOs and WASHCOs. Without strong promotion through official channel by RWB's, a private entity may not earn enough credibility from ZWOs, WWOs and WASHCOs.

The fundamental limitation of this model is that RWB's cannot control a private entity to be operating a SP outlet. Different from ZWOs, and WWOs, any private entity is not the subordinate organization of RWB's. Moreover, in case of a SP outlet established by the seed SP provision model, RWB's can confiscate the seed SPs if the SP outlet does not follow the agreement among RWB's, the ZWO, and the organization. This can be used as a leverage to control the SP outlet. Yet, this cannot work in the no-seed SP model. Therefore, a private entity may stop selling SPs if it judges this is not profitable business. Details of strengths and weaknesses of this model are shown in Table 5-5.

**Table 5-5: Strengths and Weaknesses of No-seed SP Model**

Criteria	Strengthens	Weakness
<b>Relevance</b>	<ul style="list-style-type: none"> <li>▪ In principle, SP should be supplied by the private sector</li> </ul>	<ul style="list-style-type: none"> <li>▪ Private entities may not deal SP where the demand is too low to generate sufficient benefit.</li> </ul>
<b>Effectiveness</b>	<p>The shops will be opened many of the times due to the possibility of selling construction materials which are frequently needed by communities. And there is a high possibility of getting the shops opened when WASHCOs come to procure spares.</p>	<ul style="list-style-type: none"> <li>▪ Private entities may not keep the stock of SPs which are less in demand.</li> <li>▪ No one is familiar with SPs and HPs (There are some exceptions).</li> </ul>
<b>Efficiency</b>	<ul style="list-style-type: none"> <li>▪ Private entities can freely manage the sales.</li> <li>▪ RWBs can save the cost of seed SPs.</li> <li>▪ Time and costs for training and supervising staff may be minimal, because;               <ul style="list-style-type: none"> <li>• Staff have skills of accounting and stock management.</li> <li>• Sense of maintaining sufficient stock is high, and SPs are restocked voluntary.</li> </ul> </li> </ul>	<ul style="list-style-type: none"> <li>▪ More costs for promoting the SP outlet are necessary, because a private entity may be less known by WASHCOs than TWS or Water Offices.</li> </ul>
<b>Sustainability and expandability</b>	<ul style="list-style-type: none"> <li>▪ If the demand and business chance is seen, private firm start dealing SPs without any suggestions and facilitation by RWBs.</li> </ul>	<ul style="list-style-type: none"> <li>▪ Private entities may stop selling SPs if they regard this business is not profitable.</li> </ul>

**5.2.4.2 Seed SP Provision Model**

In case of establishing a SP outlet by applying the seed SP provision model, Regional Water Bureaus (RWBs) procures and provides the initial stock of SPs for the outlet. The volume and variety of seed SPs can be calculated based on the number and types of HPs in the target area and average sales of SPs per 100 HPs per year. Basically, the ideal cycle of restocking is 1 year; however the sale of the 1<sup>st</sup> year is generally higher than after the 2<sup>nd</sup> year at any SP outlet. Therefore, the volume of seed SPs should be as much as the stock for 1 and half year. Example of the seed SPs for Afridev and Indian mark-II hand pumps presented in Table 5.6.

**Table 5-6: Examples of lists of seed SPs for Afridev and Indian Mark-II SPs****a) Afridev hand pump**

Target Region			Region - X			
Target Area			X-Zone in the region	Y-Zone in the region	Z-Zone in the region	T-Zone in the region
No. of Afridev			120	150	180	200
No.	SP Name	SP/100 HPs/Year	Number of Initial stock			
1	O - Ring	3				
2	U - Seal	10				
3	Bobbin	1				
4	Plunger	1				
5	Foot Valve	4				
6	Bush Bearing	8				
7	Rod Centralizer	15				
8	Fulcrum Pin	1				
9	Cylinder Assembly	1				
10	PVC Pipes	4				
11	Coupling for PVC pipes	40				
12	Rod	4				
13	Rod Hanger Pin	1				
14	Nylon Rope	1				



Target Region			Region - X			
Target Area			X-Zone in the region	Y-Zone in the region	Z-Zone in the region	T-Zone in the region
15	Cement Solvent	3				
16	Solvent Cleaner	3				
17	PVC pipe Centralizer	4				

**b) Indian Mark - II hand pump**

Target Region			Region - X			
Target Area			X-Zone in the region	Y-Zone in the region	Z-Zone in the region	T-Zone in the region
<b>No. of Indian Mark - II</b>			<b>110</b>	<b>80</b>	<b>60</b>	<b>130</b>
No.	SP Name	SP/100 HPs/Year	Number of Initial stock			
1	Chain	3				
2	Piston	1				
3	Bearing	1				
4	Cylinder	1				
5	Rubber Sealing	2				
6	Socket (coupling)	2				
7	Sealing Ring	1				
8	Upper Foot Valve	1				
9	Head Bolt and Check Nut	7				
10	GI Pipes	2				
11	Road	2				
12	Cup Seal	1				

Note: The numbers of HP are only those functional and repairable

The prices of seed SPs are calculated based on purchasing prices of SPs and costs for operating SP outlets. Even if a public organization such as water offices or TWS operate a

SP outlet, the prices of SPs should not be the same as purchasing prices with the following reasons; i) SPs to be restocked will become decreased unless inflation is considered, ii) prices not including costs for operation and restocking will be lower than those of private sector and it will interfere with private shops from entering the market. Therefore, the following factors should be considered to decide the selling prices of seed SPs.

- ✓ Purchasing prices of seed SPs
- ✓ Expected operation costs for 1 year: receipt printing, photocopy, telephone, etc.
- ✓ Expected costs for restocking: transportation
- ✓ Contingency costs
- ✓ Inflation: 5-10% price escalation

Transportation cost for restocking is the largest among all types of costs and it is different depending on the distance between a SP outlet and Region Capitals/Addis Ababa. As a result, the prices of SPs are different outlet by outlet as shown in Table 5-7. The formant for SP price calculation is shown in Annex- 1.

**Table 5-7: Price lists of seed SPs for Afridev and Indian Mark-II SPs**

**a) Afridev hand pump SPs**

Target Region			Region - X			
Target Area			X-Zone in the region	Y-Zone in the region	Z-Zone in the region	T-Zone in the region
No.	SP Name	Purchasing Price (Birr)	Unit Price (Birr)			
1	O - Ring					
2	U - Seal					
3	Bobbin					
4	Plunger					
5	Foot Valve					
6	Bush Bearing					
7	Rod Centralizer					
8	Fulcrum Pin					
9	Cylinder Assembly					
10	PVC Pipes					
11	Coupling for PVC pipes					
12	Rod					

**Community Based Operation and Maintenance Management Manual for Rural Point Water Supply Schemes**

Target Region			Region - X			
Target Area			X-Zone in the region	Y-Zone in the region	Z-Zone in the region	T-Zone in the region
13	Rod Hanger Pin					
14	Nylon Rope					
15	Cement Solvent					
16	Solvent Cleaner					
17	PVC pipe Centralizer					

**b) Indian Mark - II hand pump SPs**

Target Region			Region - X			
Target Area			X-Zone in the region	Y-Zone in the region	Z-Zone in the region	T-Zone in the region
No.	SP Name	Purchasing Price (Birr)	Unit Price (Birr)			
1	Chain					
2	Piston					
3	Bearing					
4	Cylinder					
5	Rubber Sealing					
6	Socket (coupling)					
7	Sealing Ring					
8	Upper Foot Valve					
9	Head Bolt and Check Nut					
10	GI Pipes					
11	Road					
12	Cup Seal					

In this model, RWBs provide seed SP to an organization to open its SP outlet. As it is not relevant to provide SP with free to a private entity for it to start selling SP, this model can be applied only to TWS and Water Offices.

### (1) Town Water Supply (TWS)

Generally speaking, the human resources of TWS are more suitable than those of Water Offices to operate a SP outlet. TWS is a profit making public enterprise, so the staff are accustomed with commercial activities such as selling, accounting, restocking and managing stock. Time and energy for training the staff is shorter and smaller than those for training the staff of Water Offices. However, their business mind is weak, because they are government employees and profit of TWS does not basically affect their salary. On the other hand, this aspect enables TWS to deal SP where the demand of SPs is low. Though TWS does not manage HPs, most of TWS does not oppose to deal SPs.

Based on the human resources who accumulate experiences of commercial activities, it should be concluded that this is the best model to be applied where sufficient demand of SPs doesn't exist to attract a private firm. Details of strengths and weaknesses of this model are shown in Table 5-8.

**Table 5-8: Strengths and Weaknesses of Seed SP Model (TWS)**

Criteria	Strengthens	Weakness
<b>Relevance</b>	<ul style="list-style-type: none"> <li>▪ TWS can supply SPs even if the demand is too low to attract private sector.</li> <li>▪ TWS can freely manage the sales without any permission from BoFED</li> </ul>	<ul style="list-style-type: none"> <li>▪ In principle, SP should be supplied by the private sector</li> </ul>
<b>Effectiveness</b>	<ul style="list-style-type: none"> <li>▪ Various kinds of seed SPs will be prepared by RWBs</li> </ul>	<ul style="list-style-type: none"> <li>▪ No one is familiar with SPs and HPs (There are some exceptions).</li> </ul>
<b>Efficiency</b>	<ul style="list-style-type: none"> <li>▪ TWS can freely manage the sales without promotion hence costs are less than those of private entities.</li> <li>▪ Time and costs for training staff are less than those of water offices;</li> <li>▪ Staff have skills of accounting and stock management.</li> </ul>	<ul style="list-style-type: none"> <li>▪ Preparation of seed SPs is the largest cost to establish a SP outlet.</li> <li>▪ Time and costs for facilitating restocking are necessary, because. <ul style="list-style-type: none"> <li>➢ The salary of staff is provided by government and nothing to do with sales of SPs, they have weak business mind</li> </ul> </li> </ul>
<b>Sustainability and expandability</b>	<ul style="list-style-type: none"> <li>▪ As long as the office exists, SPs will be sold continuously as a part of its regular activities.</li> </ul>	

### (2) Water Offices

It is clear that this model has some merits such as high recognition of water offices as a responsible organization for water issue, and their knowledge of SPs and HPs. On the other hand, some demerits are also seen i.e. water offices do not engage in commercial activities such as selling, keeping stock, recording, restocking of SPs, and thereby they do not have a sense of business mind. This requires a longer time to train the staff for them

to operate their SP outlet. Moreover, selling SPs at government offices is contradictory to RWB's principle that the private sector should supply SPs. More details of strengths and weaknesses of this model are shown in Table 5-9.

**Table 5-9: Strengths and Weaknesses of Seed SP Model (Water Offices)**

Criteria	Strengthens	Weakness
<b>Relevance</b>	<ul style="list-style-type: none"> <li>▪ Water Offices can supply SPs even if the demand is too low to attract private sector.</li> </ul>	<ul style="list-style-type: none"> <li>▪ In principle, SP should be supplied by the private sector</li> </ul>
<b>Effectiveness</b>	<ul style="list-style-type: none"> <li>▪ Various kinds of seed SPs will be prepared by RWB's</li> <li>▪ Experts of SPs and HPs exist</li> </ul>	<ul style="list-style-type: none"> <li>▪ No one is familiar with SPs and HPs (There are some exceptions).</li> </ul>
<b>Efficiency</b>	<ul style="list-style-type: none"> <li>▪ Promotion costs are minimal</li> </ul>	<ul style="list-style-type: none"> <li>▪ Time consuming process is necessary to get permission from BoFED to open a bank account for managing sales of SPs.</li> <li>▪ Preparation of seed SPs is the largest cost to establish a SP outlet.</li> <li>▪ Time and costs for training and supervising staff may be larger than those of other models, because;               <ul style="list-style-type: none"> <li>➢ Staff do not have skills of accounting and stock management.</li> <li>➢ The salary of staff is provided by government and nothing to do with sales of SPs, they have weak business mind</li> </ul> </li> </ul>
<b>Sustainability and expandability</b>	<ul style="list-style-type: none"> <li>▪ As long as the office exists, SPs will be sold continuously as a part of its regular activities.</li> </ul>	

### 5.2.4.3 Recommended Models

If a sufficient demand of SPs exists, SPs should be sold by private entities without providing any seed SPs. They are accustomed with commercial activities and motivated to sell, so costs and time for training and supervision will also be economized. However, promotion of the SP outlets should be assisted by Water Offices.

TWS is a suitable organization to establish a SP outlet by applying seed SP provision model where demand of SPs is too low for private entities. The staff of the SP outlet is more accustomed to accounting and stock management than that of water offices. If TWS doesn't exist in a selected location to establish a SP outlet, water offices will be the last option. It is because of not only the relatively less experienced staff but also minimizing the intervention of pure government organizations in market activities.

Overall evaluation results of the two models and three recommended organizations are summarized in Table 5-8. The priority of these recommended models according to market conditions is shown in Table 5-10.

**Table 5-10: Overall evaluation results of the models and recommended organizations**

SP outlet Models		No-seed SP model	Seed SP provision model			
			Private entities	TWS	Water Offices (ZWOs/WWOs)	Newly created WASHCO cooperative
Evaluation criteria						
<b>Relevance</b>	Validity of selling SPs	Good	Fair	Poor	Good	Good
<b>Effectiveness</b>	Variety of stocked SPs	Poor	Good	Good	Good	Good
	Knowledge of SPs and HPs	Poor	Occasionally good	Good	Poor	Good
<b>Efficiency</b>	Time to open a new bank account	Good	Good	Poor	Fair	Very poor
	Cost of seed SPs	Good	Poor	Poor	Poor	Poor
	Cost of training staff	Good	Fair	Poor	Very poor	Very poor
	Cost of supervision, e.g. facilitation of restocking	Good	Poor	Poor	Very poor	Very poor
	Cost of promotion	Poor	Fair	Good	Good	Poor
<b>Sustainability</b>	Continuity to sell	Good if demand exists	Good	Good	Poor	Poor
	Self-expandability	Good if demand exists	Poor	Poor	Poor	Poor
<b>Overall evaluation</b>		1 <sup>st</sup> priority (if demand exists)	2 <sup>nd</sup> priority	3 <sup>rd</sup> priority	Not recommended	

Source: The Water Sector Capacity Development Project in the SNNPRS, JICA, December, 2011

**Table 5-11: Suitability of each model depending on Market Condition**

Market condition			No-seed SP model	Seed SP provision model	
No.	HPs in the surrounding area	Financial capacity of WASHCOs	Operated by private entity	Operated by TWS	Operated by ZWO/WWO
1	Many*	High**	1 <sup>st</sup> priority	2 <sup>nd</sup> priority	3 <sup>rd</sup> priority
2	Many	Low	-	1 <sup>st</sup> priority	2 <sup>nd</sup> priority
3	Not many	High	-	1 <sup>st</sup> priority	2 <sup>nd</sup> priority
4	Not many	Low	-	1 <sup>st</sup> priority	2 <sup>nd</sup> priority

Note: \*Many: More than 200 HPs in total are located in the surrounding Woredas of a SP outlet

\*\*High: More than 80% of WASHCOs collect water tariff

## 5.3 Principles of Planning SP Outlet Allocation

The objective of this section is to show the way to increase the number of SP outlets so that all WASHCOs have an access to SPs. In section 5.3 and 5.4, SP allocation planning method and consequent allocation plan to be implemented by RWB's are presented respectively. In case that SP outlets are to be established with the initiation of organizations other than RWBs, those SP outlets should be established and operated in line with this guideline.

### 5.3.1 Universal Access to SPs

As water resources policy implementation, WASHCOs have to purchase SPs to repair their HPs. To make this materialized, WASHCOs must be strengthened enough to collect water tariff from users, and also SPs must be available at accessible location to WASHCOs at reasonable prices. RWB has a responsibility to meet the two conditions. As for the availability of SPs, RWBs should establish SP outlets at accessible location to all WASHCOs in principle.

### 5.3.2 Appropriate Distance

#### (1) Accessible Distance

The accessible location for a WASHCO to a SP outlet may differ depending on the conditions of an access road, public transportation, capacity of a WASHCO, assistance from WWOs<sup>2</sup>, etc

Based on the experiences, it has been observed that most of the customers come from a Woreda in which a SP outlet is located and its neighboring Woredas. Therefore, it should be regarded that the accessible distance for customers to visit a SP outlet is around 50 Km on an all weather road.

#### (2) Negative Effects from too many SP outlets

It is clear that closer the distance between a WASHCO and SP outlet more convenient for the WASHCO. In other word, more SP outlets established more convenient for

<sup>2</sup> WASHCOs often ask WWOs to visit the nearest SP outlet and buy SPs when a mechanic from a WWO visit a WASHCO and determine necessary SPs. The WASHCO give him money for purchasing the SPs and per diem for him.

WASHCOs. However, such situation will entail several of the following problems such as reduction of sales per one SP outlet.

- (i) If the sales become lower, stock of SPs will be left for a longer period on shelves. Quality of rubber made SPs will be deteriorated as time goes by. In addition, shelf life of cement solvent and solvent cleaner is short.
- (ii) Lower sales means that customers visit the SP outlet less frequent. It will impede the staff of SP outlet to get accustomed to its operation.
- (iii) In case that a SP outlet is operated by a private entity, lower sales may lose motivation to sell SPs.
- (iv) Establishment of too many SP outlets will impose an excessive burden on the water public sector. Establishment, operation, and supervision of a SP outlet require a certain cost to RWB, a ZWO, and an organization to operate its SP outlet which might be TWS or WWO.

Therefore, it should be avoided to establish too many SP outlets, but prepare the SP outlet allocation plan based on the accessible distance between a SP outlet and a customer, 50 km. It implies that the distance between two different SP outlets can be 100 km as maximum on all weather roads.

### 5.3.3 Accessibility

Location of a SP outlet should be convenient for WASHCOs in its surrounding Woredas. More specifically, each SP outlet should be accessible to surrounding Woreda centers by all weather roads. The shorter the distance between a SP outlet and a Woreda center on all weather roads, more convenient for WASHCOs. Figure 5-4 shows that City A has a direct access to many other cities through all weather roads. It means City A provides convenient access to surrounding cities though it is located right end of Zone X. On the other hand, Figure 5-5 depicts that the access to City B from other cities require two trips via City A, because City B is only accessible to City A. Access to City B is less convenient than that to City A, though City B is located at the center of Zone X.

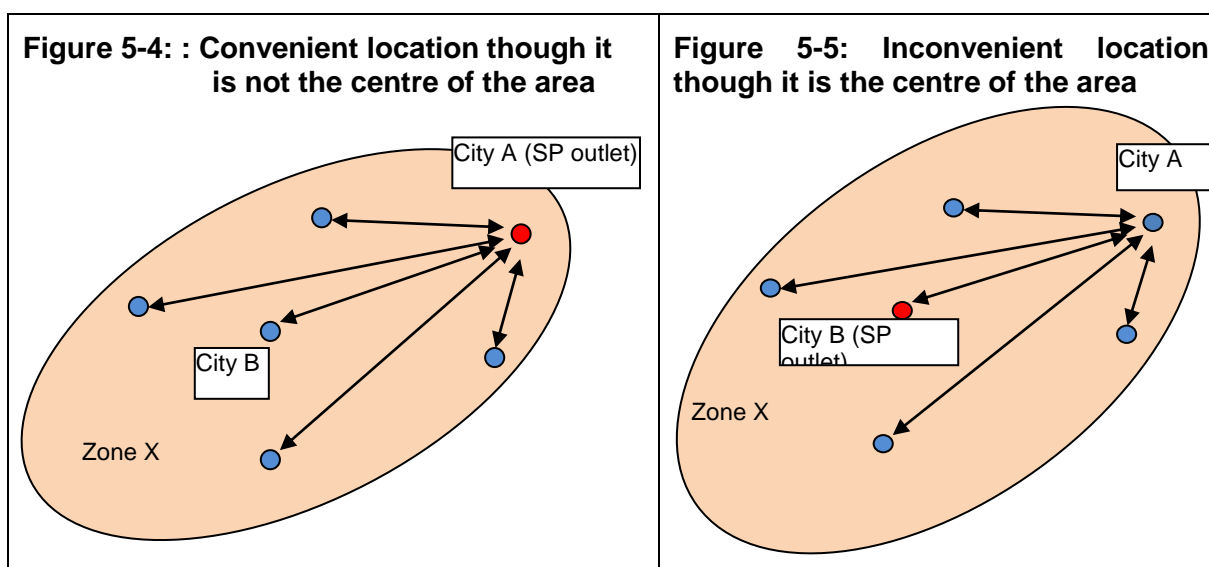

In case that there is only one major access road in a zone, the location of a SP outlet should be geographical center of the zone even though the center city is not a zonal capital. As shown in Figure 5-6 and 5-7, City B provides more convenient accessibility for WASHCOs in the zone than City A



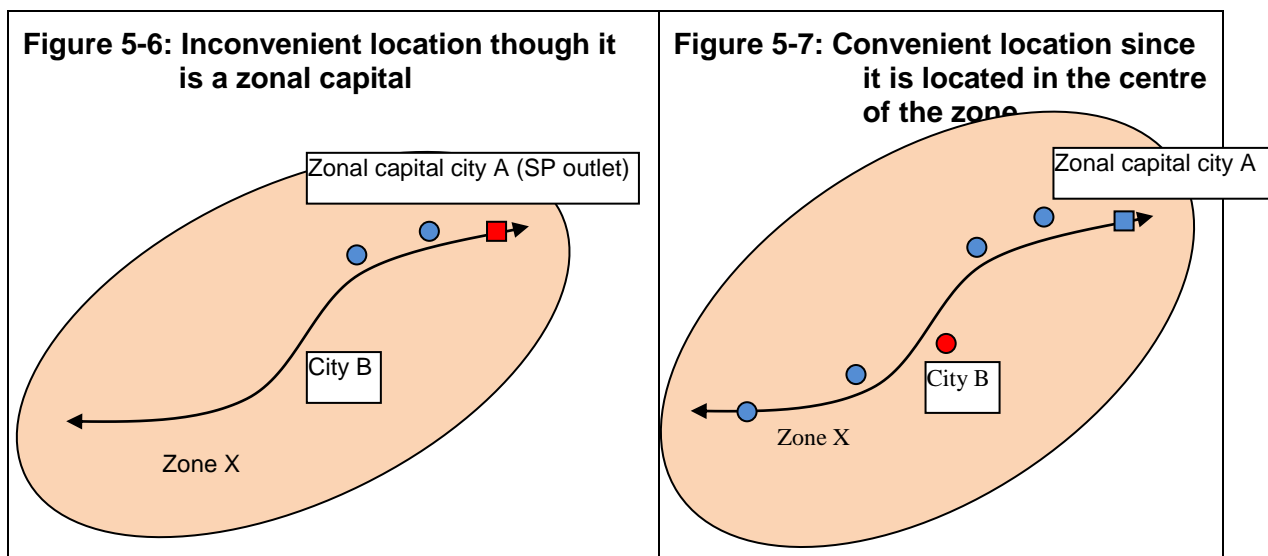

### 5.3.4 Convenience for Zone Water Offices

Zone Water Offices should bear responsibility of SP supply in their respective zones, and supervision of SP outlets in the zone is a part of it. In this regard, if a SP outlet established in zonal capital, communication between the ZWOs and SP outlet may not be limited to telephonic consultation and report submission, but frequent direct communication will be possible. This will save a cost of the supervision and improve the operation of a SP outlet. This is one of advantages of zonal capitals as a location to establish a SP outlet.

### 5.3.5 Selection of Cities/Towns

Based on the above mentioned principles of planning SP outlet allocation, priority to select cities/towns in which to establish SP outlets should be concluded as follows:

- **1<sup>st</sup> priority:** To establish 1<sup>st</sup> SP outlet in each zonal capital

First, each zonal capital is located sufficiently far from others, so it will avoid the competition of customers. Second, zonal capitals are accessible by one or more all weather roads to other cities/towns in the same zone. Third, if a SP outlet is located in a zonal capital, communication between the SP outlet and ZWO will be facilitated. Therefore, at least one SP outlet should be established in each zone.

- **2<sup>nd</sup> priority:** To establish 2<sup>nd</sup> and 3<sup>rd</sup> SP outlets in a zone

Even after establishing SP outlets at all zonal capitals, these outlets cannot provide access to all WASHCOs throughout the region. Some other SP outlets should be established in the areas which are not accessible to any SP outlets. Therefore, one or two more SP outlets may be established in some sizable zones. First, the 2<sup>nd</sup> and 3<sup>rd</sup> outlets in a zone should be located at sufficient distance from any other SP outlets. 100 km distance could be applied as a rough indicator. Second, the location should have a good access from surrounding Woredas. GIS map with road, region, zonal town, woreda can help to indicate the actual SP outlets for each respective regions.

## 5.4 SP Outlet Allocation Plan

### 5.4.1 Existing SP Outlets

Before planning SP outlet allocation for the entire region, existing SP outlets/shops must be identified. Both the private as well as the public SP outlets listed out and fill locations in the non existing SP outlets.

### 5.4.2 Preparation of Action Plan

Given the capacity of RWBs, it is not feasible to establish all necessary SP outlets for all regions at the same time. The activities for SP outlet establishment should be implemented for 5 years divided into two phases. Phase-I consists of 3 years while Phase – II for 2 years as shown in Figure 5-8. The major activities for 3 years are summarized in Table 5-11, and detailed activities of each year are shown in Figure 5.8, 5-9, and 5-10 respectively. As workload of the 3<sup>rd</sup> year is relatively lower than the 1<sup>st</sup> and 2<sup>nd</sup> year, the 1<sup>st</sup> year of the phase 2 can commence on the 3<sup>rd</sup> year of the phase 1.

Based on the recommended SP outlet models and principles for SP outlet allocation planning, during the phase 1, in total ---- SP outlets are to be established in various zones. The SP allocation plan for the phase 1 and 2 are outlined in the following two sections.

**Figure 5-8: Phases to establish SP outlets which cover the whole region**

Calendar year	2014		2015		2016		2017		2018		
Fiscal year	2013	2014		2015		2016		2017		2018	
Phase 1		1 <sup>st</sup> year		2 <sup>nd</sup> year		3 <sup>rd</sup> year					
Phase 2						1 <sup>st</sup> year		2 <sup>nd</sup> year		3 <sup>rd</sup> year	

**Table 5-12: Major Activities at each Year**

Year	Major Activities
1 <sup>st</sup> year	<ul style="list-style-type: none"> <li>Preparation and establishment of SP outlets as planned</li> </ul>
2 <sup>nd</sup> year	<ul style="list-style-type: none"> <li>Intensive supervision and refreshment training on the daily operation of the SP outlets established in the 1<sup>st</sup> year</li> <li>Training on restocking and price revision</li> </ul>
3 <sup>rd</sup> year	<ul style="list-style-type: none"> <li>Continuous supervision and necessary refreshment training of the SP outlets</li> </ul>

**Figure 5-9: Action Plan of the 1<sup>st</sup> year**

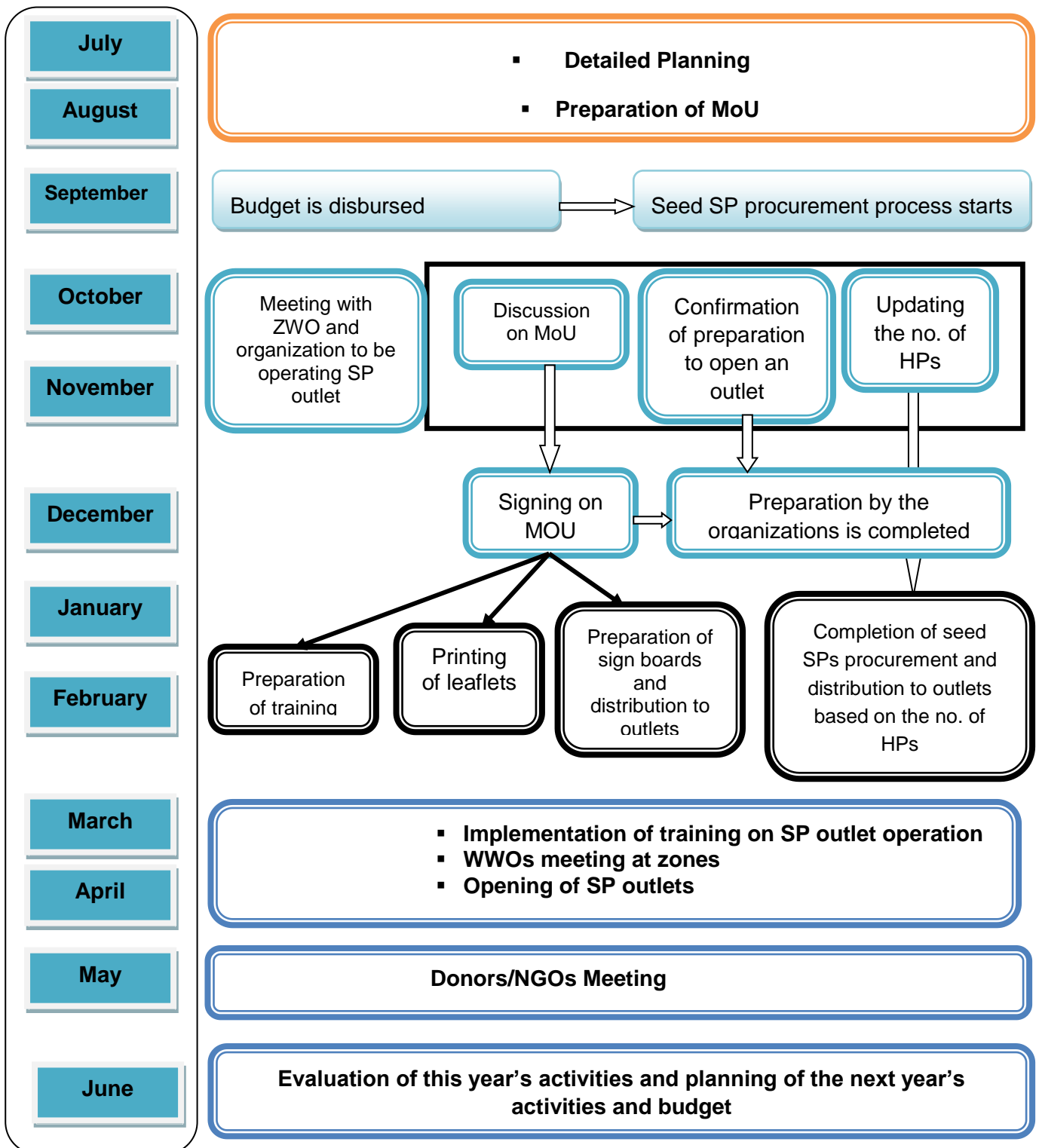

There are many activities to be conducted to establish SP outlets in the first year of each phase. Therefore, budget should be disbursed not later than September; otherwise completion of all the planned activities will be difficult. It is recommendable to conduct the training and WWO meeting at the same occasion. After the two days training and one day meeting, a SP outlet will be officially opened at each place. The donor/NGO meeting is an

important occasion to announce the inauguration of the SP outlets and facilitate them to utilize the outlets.

**Figure 5-10: Action Plan of the 2<sup>nd</sup> year**

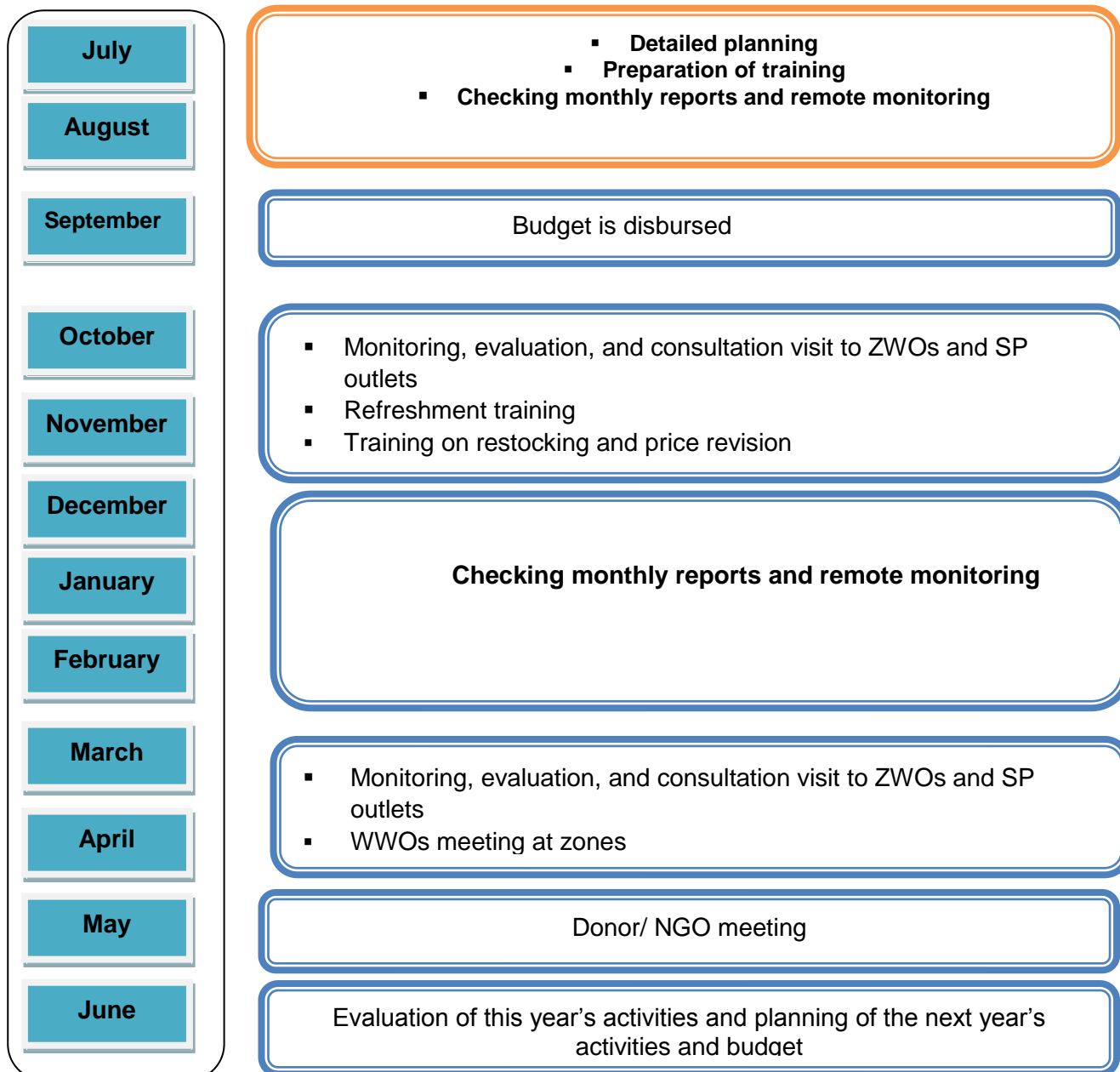

Appropriate operation of SP outlets is the main objective of the 2<sup>nd</sup> year, and therefore the monitoring, evaluation, and consultation visit will be conducted twice the year. WFOs meeting at each zone will be an opportunity to hear the comments from customers, WFOs and WASHCOs through WFOs. Those comments will be beneficial to improve the operation of SP outlets. The training on restocking and price revision is better to be provided not in the 1<sup>st</sup> year but 2<sup>nd</sup> year, because i) volume of seed SPs is as much as expected sales for 2 years, ii) it should be avoidable to provide too much information at the training in the 1<sup>st</sup> year. The donor/NGO meeting is the occasion to report the progress of SP outlets started operation in the previous year and enlist a support.

The 3<sup>rd</sup> year is a supplemental period to ensure the sustainability of SP outlets. Ability of a SP outlet for sustainable operation and capacity of a ZWO for supervising the SP outlet should be further strengthened, while intervention of RWB needs to be reduced gradually.

**Figure 5-11: Action Plan of the 3<sup>rd</sup> year**

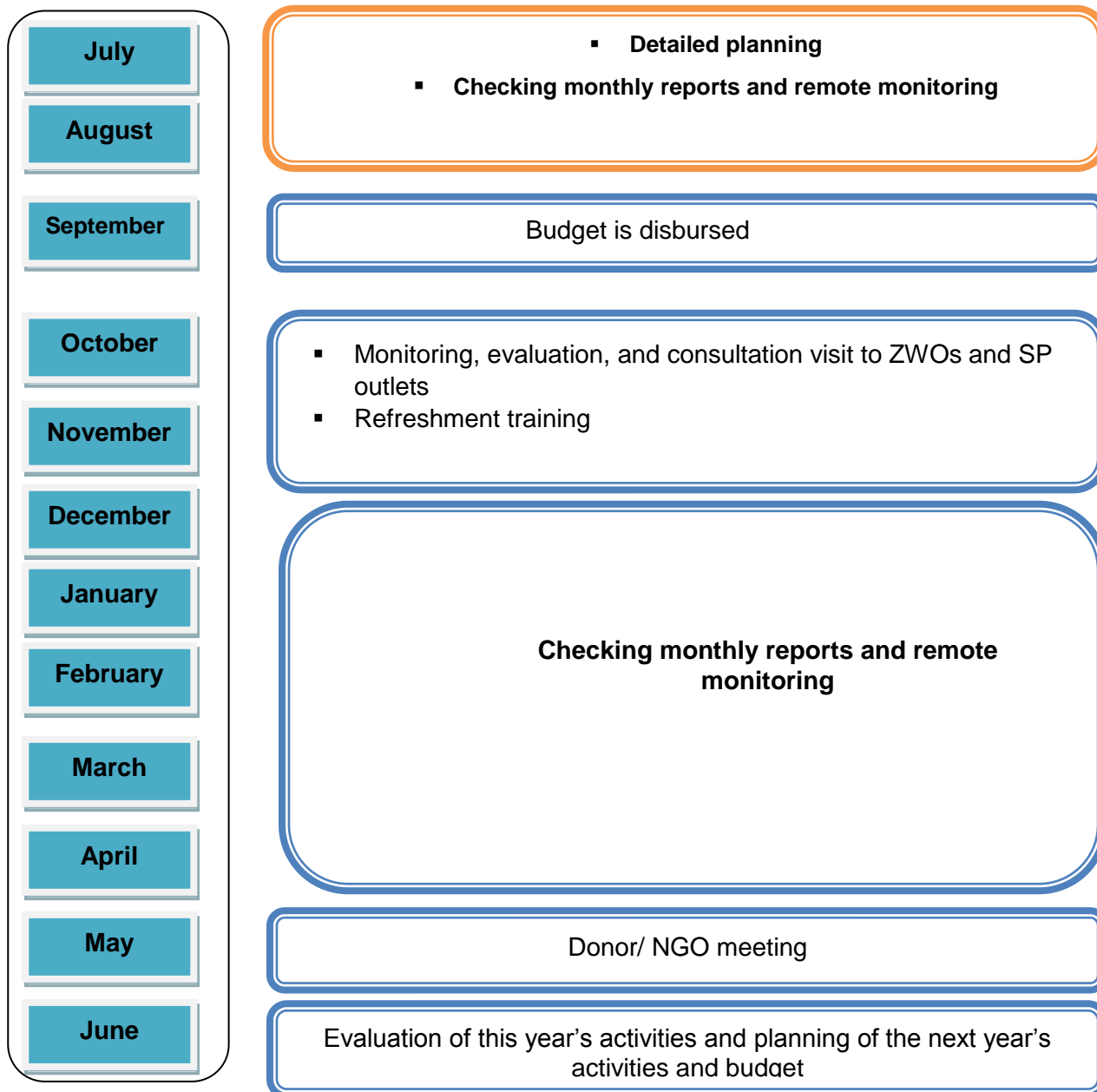

### 5.4.3 Budget Plan

Based on the activities schedule shown in Figure 5-9 to 5-11 and seed SPs shown in Table 5-6, the budget for establishing eight SP outlets is estimated as Table 5-13. Detailed budget plan from Ethiopian fiscal year 2014 until 2018 is shown in Annex- 2.

**Table 5-13: Example of Estimation budget for the next 5 years on SP outlet establishment**

Phase		Phase-I			Phase-II			Total
Fiscal Year		2014	2015	2016	2017	2018		
Item	Details	1 <sup>st</sup> year	2 <sup>nd</sup> year	3 <sup>rd</sup> year	1 <sup>st</sup> year	2 <sup>nd</sup> year	3 <sup>rd</sup> year	
<b>Seed SPs</b>	Seed SPs for --outlets	136,420	0	0	119,200	0	0	255,620.00
<b>SP storage facilities</b>	Cabinet, Containers, delivery	50,250	0	0	62,450	0	0	112,700.00
<b>Leaflet</b>	40,000 copies for 1 <sup>st</sup> year, 20,000 copies for 2 <sup>nd</sup> year	15,000	9,000	0	15,000	0	9,000	48,000.00
<b>Sign Boards</b>	Sign Board and delivery	26,250	0	0	28,400	0	0	54,650.00
<b>Visit by RWB</b>	Per-diem and transport	28,250	22,400	15,900	32,300	24,300	17,600.	140,750.00
<b>WWOs meetings</b>	Per-diem	22,550	22,550	0	16,600	16,600	0	78,300.00
<b>Donor/NGOs meeting</b>	Conference room, lunch, refreshment	14,500	14,500	0	14,500	14,500	14,500	72,500.00
<b>Maintenance &amp; vehicle</b>	Oil, spare parts, service charge etc	15,000	10,000	5,000	15,000	10,000	5,000	60,000.00
<b>Total</b>		<b>308,220</b>	<b>78,450</b>	<b>20,900</b>	<b>303,450</b>	<b>65,400</b>	<b>46,100</b>	<b>822,520.00</b>

## 5.5 Procurement and Service Linkages

Strengthening links between pumps, services and parts can increase the viability of supply chains. Procurement system recommended in this guideline must have an influence and should stipulate roles and responsibilities of each party in the supply chain within contracts. This means selecting pump suppliers locally who can provide spares and services at the lowest price and linking these in the supply chain. The government decentralization policies already encourage local procurement of pumps and spare parts, stimulating supply chains down to the community level.

The system is believed to hold the linkages from WASHCO level to the parts importers at national level. The work includes the identification of pumps and parts suppliers, their distribution systems and channels including their branch supply units, identifications and assessing local suppliers, review and assessment of enabling environment for these suppliers and finding how to stimulate supply chain down to the community level. Different approaches must be examined because some approaches and methods may have limited viability and may not increase accessibility to spare parts in sparsely populated

areas/zone where poor transportation facilities could hamper the flow of goods and people.

### 5.5.1 Alternative Spare Parts Supply Model

It is important to think about the system that spares can be found at the nearest SP outlet. In the absence of these facilities in local areas, the Growth and Transformation Plan (GTP) of the sector, without keeping the water supply schemes functionality, it will be harder to achieve.

The best alternative chosen under this guideline is expected to curb the problem encountered so far due to low access to supply chain. Two alternatives approaches are proposed for choice here. While alternative - I is concerned with the procurement of spare parts through the involvement of the government, alternative -II is the supply of spare parts through the involvement of privet sector. Both approaches are examined here below.

#### 5.5.1.1 Alternative - I: SPs Procurement through Government Channels

One way in which institutions can influence sustainability is to develop appropriate procurement strategies. Currently, the government and NGOs purchase handpumps, directly from manufacturers.

The government offices such as the Water Bureaus normally control procurement of supply items. The procurement procedure is guided by the Federal Finance Guideline, which focuses on competitive open bidding where by low cost and good quality products are supposed to be purchased.

It is true that government targets and plans for increasing rural water supply coverage include a decentralized, demand responsive approach to service delivery, responsibility by users for O&M and cost-recovery and exerts maximum efforts to optimize service coverage. As regards to supply chain, this approach has its own advantage and disadvantages as illustrated in Table 5-10.

**Table 5-14: Advantages and Disadvantages of SPS procured through Government**

Advantages	Disadvantages
<ul style="list-style-type: none"> <li>▪ Cost advantages achieved from bulk purchases realized through government bidding process</li> <li>▪ Better quality choice of parts</li> </ul>	<ul style="list-style-type: none"> <li>▪ Hampering government procurement procedures and bureaucracies,</li> <li>▪ Possibility of giving less attention to procure these parts because of overstretching themselves in other assignments</li> <li>▪ Difficulty of storage facilities and store management systems,</li> <li>▪ Rigid government financial regulations delays procurement</li> <li>▪ Lack of human power specialized in procurement at all levels</li> <li>▪ There is minimal opportunity for local innovation to develop appropriate and sustainable technologies.</li> <li>▪ There are likely to be extensive time delays from order date to delivery date</li> <li>▪ There is likely to be a lack of direct quality control (resulting in high levels of rejected parts) and limited consultation with the manufacturer.</li> </ul>

### 5.5.1.2 Alternative II: Supply through Privet Sector

Private-sector involvement in supply chain has not been tried as such on a large scale. Attempts could be made to encourage privet suppliers or artesian associations to play intermediary roles and promote spare parts outlets or could let them add parts to their product line and avail them to rural water supply schemes in the area.

**Table 5-15: Advantages and Disadvantages of SPS procured through Private sector**

Advantages	Disadvantages
<ul style="list-style-type: none"> <li>▪ Better efficiency in delivering spare parts</li> <li>▪ Less burden to the government and rural communities</li> <li>▪ Better access to supply chain and minimal non-functionalities of water points</li> </ul>	<ul style="list-style-type: none"> <li>▪ Attempts to encourage private sector supply chains may have limited success due to low commercial viability,</li> <li>▪ Possibilities of higher purchase prices in relative,</li> <li>▪ Lack of capacity to hold slow moving parts for long time where cash is tied up in low productive business.</li> </ul>

### 5.5.1.3 Recommended System for Supply Chain

Alternative private sector involvement in supply chain have a number of advantages over the government procurement system even though they are not always more effective. The choice depends on the local context. The procurement of parts is recommended to fully involve the privet sector. The government implementing agencies as specified in the following sections have their own roles and responsibilities to materialize the creation of smooth supply chain.

The consultant believes that the recommendation of involving privet sector for the supply chain is harmonized with the intension of the government. According to this initiative, the federal and local government institutions capacity will be enhanced; artisans who will be trained and assisted to establish companies; and the entrepreneurs who will benefit from selling spare parts. Here in this document privet sector can be defined as the privet shop dealers and the artesian associations which have legal personality to do business.

In Amhara region, the Community Development Fund (CDF) approach also recommended that promoting the private sector is the most sustainable and long term solution to spare part access problems.

Since it will not be possible to establish all the sub-regional dealers the initial supply chain could have the following structure:

- 2 to 4 national suppliers,
- 4 regional depots (modelled along the 4 regions selected for the piloting)
- about 5 to 8 sub-regional dealer outlets per region
- Each entering into an agreement with 1-2 dedicated/certified hand pumps installation-servicing technicians (TSP),
- The sub-regional outlet together with the TSP and the contractors will install/rehabilitate hand pumps and sign annual maintenance contracts with the community (WASHCO). Each WASHCO will appoint 1-2 village caretaker who will be trained/or re-trained by the certified TSP or the WWO.
- The supplier shall establish and maintain regional depots and spare part outlets in the locations specified for each of the geographical areas. In these shops the general



public can purchase parts during normal business hours. The spare parts inventory at each SRD shall not drop below 25% for any item listed in the recommended spare parts requirements, and shall never be completely depleted. The WWO will check the inventory at least once every three months, and invoke the punitive measures specified in the contract if the supplier does not maintain the minimum required inventory.

- This strategy will create business opportunities for the supplier, spare parts outlets, certified technician and village caretakers. The initial tender should establish about a two-year stock of new pumps with the necessary appropriate spare parts kits.

Five key factors for successful and sustainable private sector supply chains:

1. Adequate demand
2. Effective stakeholder incentives
3. Effective information flow
4. Effective supply chain management
5. An enabling environment

**Figure 5-12: Proposed Supply Chain of RWS Scheme Spare parts**

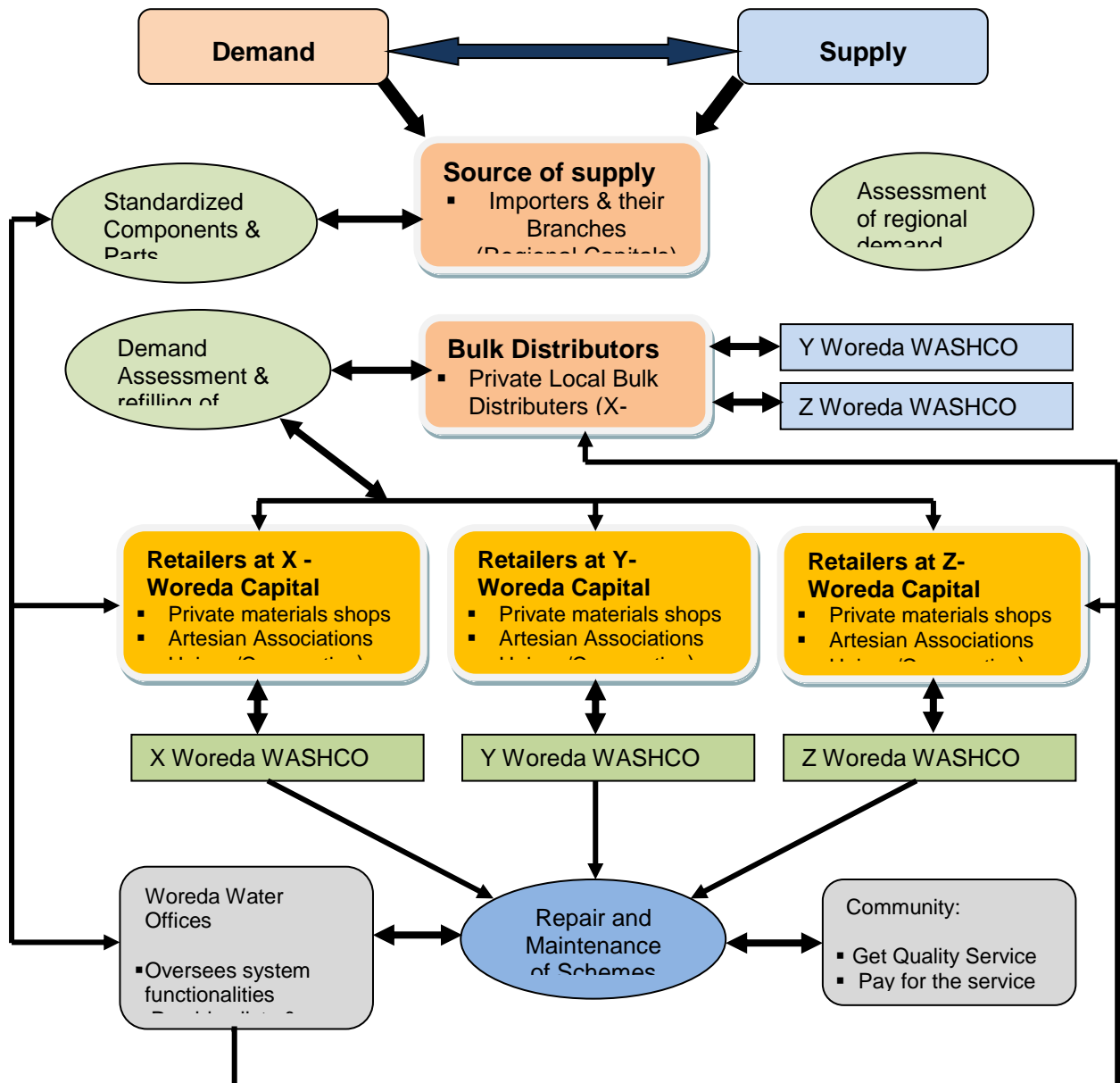

**a) Low Cost Pump**

The low cost technology pumps (rope pumps) can easily be produced in Ethiopia and their Supply Chain should be short and uncomplicated.

These pumps are also part and parcel of Self Supply, a concept that has been adopted by the Government of Ethiopia. In this concept, water users are buying their own hand pumps directly from the workshops nearby. Thus, a very short Supply Chain is created.

**Figure 5-13: Supply Chain for Rope Pump**

Such a Supply Chain does not need a specific management system, no subsidies are involved and if after sales services are required the user knows exactly where he has to go. For the introduction of the technologies, it might however be useful to provide some start up booster support. Any such support should be limited in time and should have an exit strategy from the very beginning.

Also it is recommended to set minimal performance standards for these rope pumps. And even more important, to inform the professionals in the sector about the limitations of these pumps. Low cost technologies are limited in lift (usually not more than 10-12 metres) and in utilization (families need 100 to 200 litres of water per day). If these pumps are subject to heavy working conditions they break frequently and will be abandoned by the users soon.

**b) Local manufacture of spare parts**

Whether pumps are manufactured in country or elsewhere, government and donors should buy as possible as from local, e.g. in a Woreda capital rather than the national capital. Where local retailers sell pumps they are more likely to ensure that they also stock spare parts, making these available close to communities.

Institutional strategies should, where possible, incorporate the following components:

- In-country quality control of equipment;
- Purchase of handpumps at Woreda level; and
- Support to grassroots innovation and manufacture.

The small workshops involved in the production of low cost pumps would also be ideal partners for the national importers of community pumps (Afridev, India Mark-II). The supply chain for these pumps can be created when the national supplier and the local workshop enter into a contract to sell spare parts and community pumps. The setting up of such a contract is described later in the report.

Such an arrangement can work well as private sector workshops do have the necessary technical knowledge and skills to provide the necessary after sales services, like sales of spare parts, technical support to WASHCO, and even the WWO. They can also perform repair services. Contracts between the national supplier and the local workshop/outlet could include that the local shop sells the spare parts on commission, thus the problem of restocking would be solved as the small local shop does not require investing cash into buying spares.

## 5.6 Steps to Establish a SP outlet

Based on the SP outlet allocation plan, RWBs will establish the SP outlets, make them operational, and supervise them through the process shown in the figure below. Cooperation and commitment of key stakeholders are necessary in the process of establishment, and RWB is responsible for coordination and facilitation of the process. The key stakeholders are an organization is to operate the SP outlet, ZWO of a zone, and WWOs of the zone.

**Figure 5-14: Steps to Establish a SP outlet**

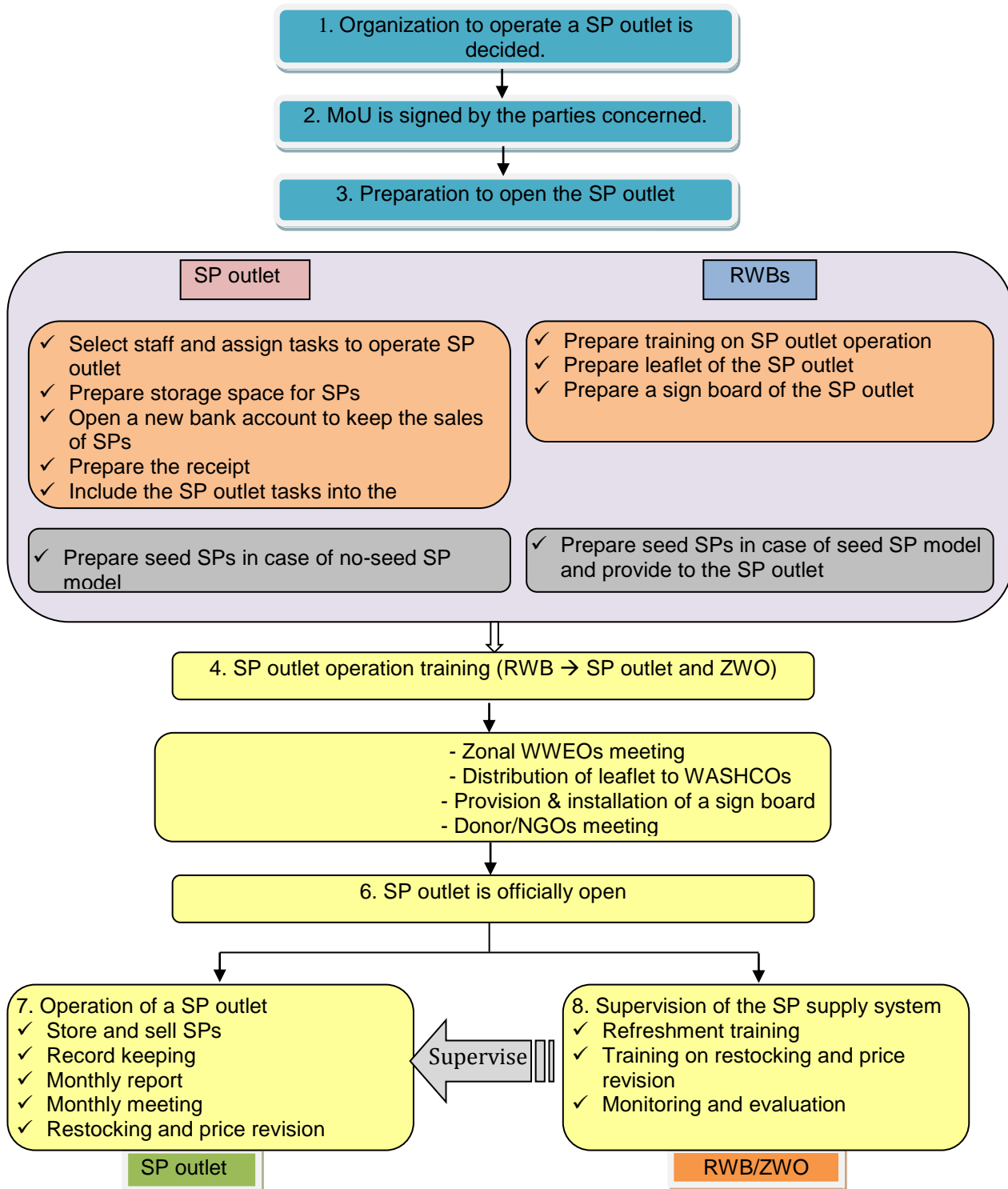

### 5.6.1 Organization to operate a SP outlet is decided

In the plan of SP outlet allocation detailed above, locations (cities/towns), candidate organizations and their priority to establish SP outlets are all specified. The next step is to determine an organization which will operate its SP outlet in line with the flowchart shown in Figure 5-15. RWB and the ZWO should start dialogue with the listed candidate organizations to confirm their capacity and intention to operate the SP outlet.

**Figure 5-15: Flow of selecting Organization to operate SP outlet**

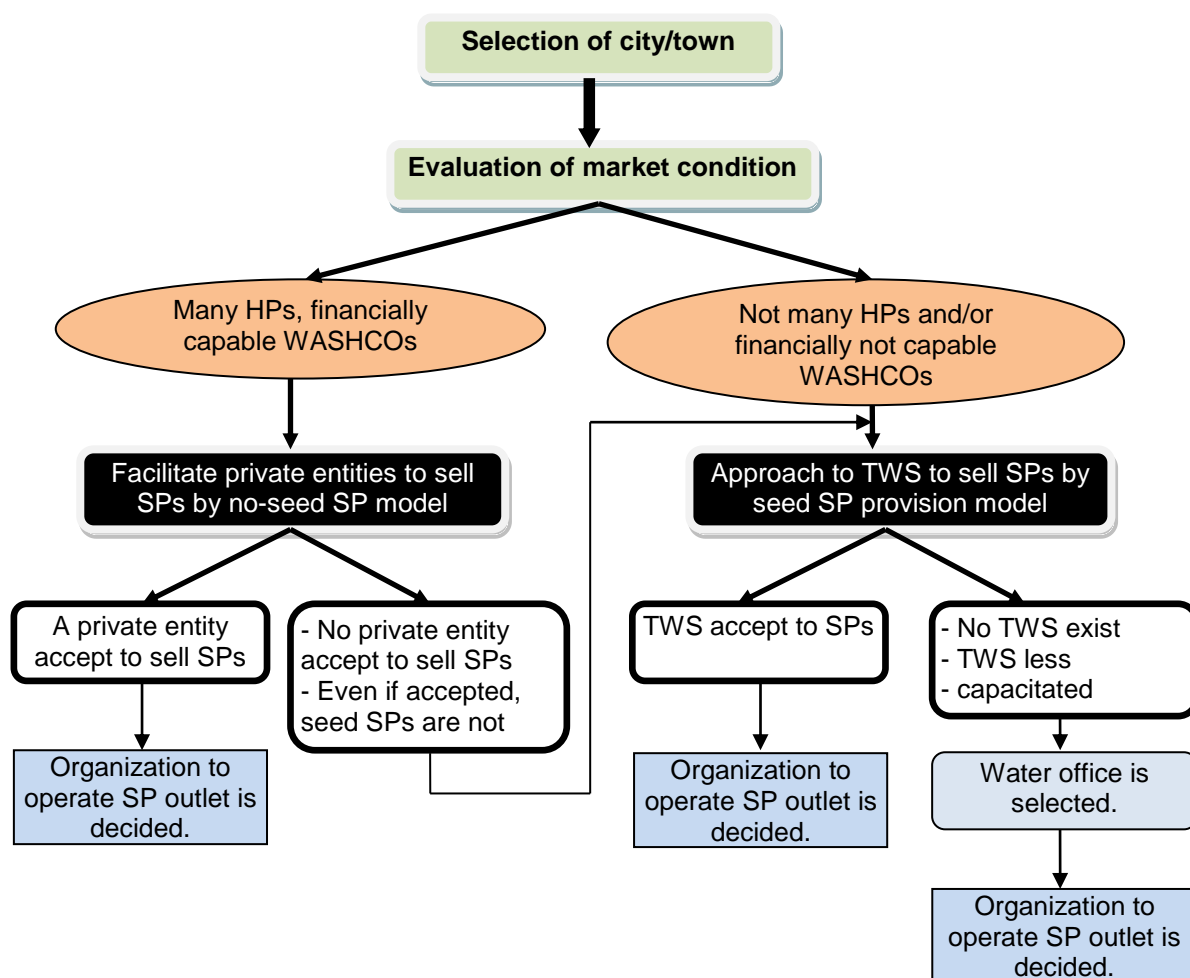

The capacity to operate a SP outlet consists of human resource and facilities as shown in Table 5-16. In order to confirm the intention to operate a SP outlet, it is recommendable to explain the outline of the memorandum of understandings (MoU).

**Table 5-16: Necessary Human Resources and Facilities for an Organization to operate a SP outlet**

Items	Key question	Details
<b>Human resource capacity</b>	Is appropriate staff to operate SP outlet available?  *Mechanic is not an absolute requirement	<ul style="list-style-type: none"> <li>▪ Manager: a person who is responsible for and has an authority to control the entire organization. An office head in case of a public organization and owner in case of a private entity are suitable.</li> <li>▪ Accountant: a person who has skills and knowledge of accounting, or who is motivated and capable to learn the skills and knowledge.</li> </ul>

Items	Key question	Details
		<ul style="list-style-type: none"> <li>▪ Storekeeper: a person who has skills and knowledge of stock management, or who is motivated and capable to learn the skills and knowledge.</li> <li>▪ Mechanic: a person who has a skills and knowledge of SPs and HP repair, or who is motivated and capable to learn the skills and knowledge.</li> </ul>
<b>Facilities</b>	Is appropriate storage space available?	A room with rocking system, area should be larger 3m x 4 m

In case of the no-seed SP model, private entity to be operating SP outlet prepare less various kinds of initial stock of SP comparing to the seed SP provision model. The entity may intend to increase a variety of SPs little by little reacting to demand. However, less various stocks might disappoint customers and discourage them to come to the SP outlet. Therefore, initial stock of SPs should be various at least about 10 kinds, even if the small volume of each item is prepared. RWB should appropriately show a private entity the expected demand size of SPs by referring sales records and the number of HPs of a SP outlet established. The planned seed SPs depicted in Table 5-5 might be a useful data to explain a demand size, because the volume of seed SPs represents the expected sales volume for a year at each target area. The volume and kinds of the initial stock of SPs must be agreed and specified on MoU.

If the private entity is not willing to prepare various kinds of initial stock, RWB should close the negotiation with the entity and then approach to TWS.

## 5.6.2 MoU is signed by the parties concerned

### a) Signatories of MoU

Once an organization to be operating its SP outlet is determined, MoU should be agreed and signed by parties concerned to the outlet. The parties concerned vary depending on the organization to be operating its SP outlet as shown in Table 5.17.

**Table 5-17: Parties concerned to sign MOU**

Organization to be operating its SP outlet	Parties concerned to sign MoU
<b>Private entity/TWS</b>	RWB, ZWO, Private entity/TWS
<b>ZWO</b>	RWB, ZWO
<b>WWO</b>	RWB, ZWO, WWO

### b) Contents of MoU

MoU is a document which explains the system of SP supply through a SP outlet and states responsibilities of the parties concerned, etc. The contents of MoU are summarized in Table 5.18.

**Table 5-18: Contents of MOU**

Chapter	Contents
<b>I. Purpose</b>	Briefly presenting its objective
<b>II. Spare Parts Supply System</b>	Explaining the system of supplying SP through a SP outlet based on cost compensation by WASHCOs. The system is shown in Annex- I.
<b>III. Target Area and</b>	Presenting the area from which expected customers are located.

Chapter	Contents
<b>Target Customers</b>	However, any customer from anywhere is welcomed.
<b>IV. Period of Agreement</b>	Meaning the necessary period for a SP outlet to acquire sufficient experiences to operate its outlet by itself. During the period, supervision by RWB and ZWO should be intensive.
<b>V. Responsibilities of the Parties</b>	1. The RWB 2. The SP Outlet 3. The ZWO/WWO
<b>VI. Modification</b>	Mentioning MOU is amendable if the parties agree it.
<b>VII. Dissolution of Agreement</b>	If the responsibility of each party is not fulfilled, the agreement might be dissolved. In particular, if a SP outlet fails to perform its responsibility, provided seed SP must be returned based at RWB's request.
<b>Annex- A</b>	Basic Concept of the Spare Parts Supply System
<b>Annex-B</b>	List of Seed Spare Parts and Prices

### c) Responsibility of the Parties

The main part of MoU is item in "V". Responsibility of the Parties, in the above table. The responsibilities must be fulfilled by the parties as long as the MoU is valid. If any party fails to fulfil its responsibility, it may lead to the dissolution of the agreement. The responsibilities of the parties concerned are summarized in Table 5-19 and detailed in MoU as Annex -C.

**Table 5-19: Responsibility of the Parties Concerned**

Parties	Responsibilities
<b>RWB</b>	<ol style="list-style-type: none"> <li>(1) Provide seed SPs to an SP outlet as specified on MoU (in case the SP outlet will be established applying the seed SP provision model)</li> <li>(2) Determine the price of SPs</li> <li>(3) Provide the staff of the SP outlet with necessary knowledge and skills to operate its outlet</li> <li>(4) Obtain monthly inventory and financial reports from the ZWO, check them, and order revision if necessary to the SP outlet through the ZWO</li> <li>(5) Check, order revision if necessary, and approve a restocking proposal in consultation with the ZWO</li> <li>(6) Check, order revision and approve a price revision proposal in consultation with the ZWO</li> <li>(7) Provide the SP outlet, the ZWO, and the WWOs with technical and administrative advises and directions</li> <li>(8) Prepare leaflets and sign board to promote the SP outlet</li> <li>(9) Promote the SP outlet to WASHCOs outside the target area through relevant ZWOs and WWOs</li> <li>(10) Assist and facilitate ZWOs and WWOs to reorganize and/or strengthen WASHCOs and not to provide free SPs</li> <li>(11) Supervise the spare parts supply system in this region</li> </ol>
<b>ZWO</b>	<ol style="list-style-type: none"> <li>(1) Obtain monthly inventory and financial reports from the SP outlet, check them, order revision if necessary, and send them to RWB</li> <li>(2) Advise and facilitate the SP outlet to prepare the proposals of restocking and price revision when necessary</li> <li>(3) Check, order revision if necessary, and approve a restocking proposal in consultation with RWB</li> <li>(4) Check, order revision and approve a price revision proposal in consultation with RWB</li> <li>(5) Inform the revised prices of SPs to WASHCOs in the target area through the WWOs</li> <li>(6) Promote the SP outlet to WASHCOs in the target area through the WWOs.</li> <li>(7) Assist and facilitate WWOs to reorganize and/or strengthen WASHCOs and not to provide free SPs</li> </ol>

Parties	Responsibilities
	(8) Supervise the spare parts supply system in the target area
<b>SP outlet</b>	(1) Prepare initial sock of SPs as specified on MoU (in case the SP outlet will be established applying the no-seed SP model) (2) Open a new bank account to manage the sales of SPs (3) Revise the performance evaluation sheet of each staff to include the tasks for SP outlet operation (in case a SP outlet is operated by water offices or TWS) (4) Store and sell SPs (5) Record sales, expenditure, and stock of SPs (6) Prepare monthly inventory and financial reports and revise them according to the comments from the ZWO and RWB (7) Conduct monthly meeting among the staff (8) Restock SPs with the approval of the ZWO and RWB (9) Revise the price of SPs with the approval of the ZWO and RWB (10) Consult with the ZWO whenever necessary

#### d) Modification of the standard MoU

The standard format of MoU, which is shown as Annex - C, should be applied to any MoU. Particularly, it is not recommended to modify the part I, II, V, VI, VI, and Annex - A of MoU. One of a few amendable parts is the target area, the part III of MoU in Table 5-18. It should be decided through the discussions among the parties concerned. As to the part VI Period of agreement, three years is recommended, but it is possible to extend if the parties agree. In case of the seed SP provision model, Annex-B List of Seed Spare Parts and Prices should be prepared by RWB.

#### e) Expiration of MoU

Item IV. Period of Agreement of MoU specifies the duration for which the MoU is valid. Before expiring the period, the parties concerned should decide what to do. Basically, there are three options to be chosen as shown in Table 5-20.

**Table 5-20: Potential actions after expiration of MoU**

Actions after expiration	Descriptions	Application
<b>Leave expired</b>	All parties concerned become free from agreed items specified in MoU. However, responsibilities and obligation which are inherent to each party will remain particularly for ZWO and RWB. While many of obligations to be performed by a SP outlet will become activities on a voluntary basis.	Not recommended
<b>Extend the period</b>	The parties concerned extend the period of agreement without any amendment on MoU.	Recommended if a SP outlet operated by water offices or TWS
<b>Revise MoU</b>	The parties concerned amend MoU and agree on it. For example, if a SP outlet is operated by a private entity, obligations of SP outlet can be minimize and the pricing method can be left to the outlet.	Recommended if a SP outlet operated by a private entity

In case that a SP outlet is operated by either water offices or TWS, the period of agreement of MoU should be extended. While in case that a private entity operates a SP

outlet, MoU does not necessarily have to be extended as it is. SPs should continuously be supplied by the outlet, but the obligations of the outlet can be minimized except for those may promote the outlet. For example, the outlet should continue to record bin cards and report ZWO of prices and variety of SPs if changed. In return, ZWO need to disseminate the information to WASHCOs through WWOs. These minimum obligations have to be depicted on a revised MoU and agreed among the parties concerned.

### 5.6.3 Preparation to open a SP Outlet

#### 1) SP outlet

##### a) Select staff and assign tasks to operate the SP outlet

An organization to be operating its SP outlet selects appropriate staff and assigns them the tasks to operate the SP outlet. If the organization is TWS or water offices, the tasks related to their SP outlet should be included in the performance evaluation sheet of the staff.

##### b) Prepare a storeroom for SPs

An organization to be operating its SP outlet specifies an appropriate storeroom to keep SPs. It must be sizable enough to keep PVC pipes and rods specifically larger than 3m x 4m, equipped with lockable system, managed by a designated storekeeper, and located convenient place for the storekeeper to manage.

##### c) Open a new bank account to manage the sales of SPs

An organization to be operating its SP outlet prepares a bank account to manage the sales of SPs. The account should be used exclusively for this purpose. It is recommended to open a new bank account, and it should be avoided to use an existing bank account in which another source of money may be deposited. It will lead to inaccurate accounting.

##### d) Prepare seed SPs (in case of the no-seed SP model)

In case of the no-seed SP model to be applied, an organization to be operating its SP outlet prepares the initial stock of SPs. The volume and kinds of the stock must be specified on Annex - B of MoU.

#### 2) RWB

##### a) Prepare leaflet and sign board

RWB prepares leaflets and a sign board to promote an SP outlet. In general, it will take 4 weeks for designing and printing colored (both sides) leaflets after ordering. While 2 weeks may be necessary to complete one signboard. Design of a leaflet and signboard examples are shown in Annex-D and E respectively.

##### b) Prepare seed SPs (in case of the seed SP provision model)

In case of establishing a SP outlet by applying the seed SP provision model, RWB procures and provides the initial stock of SPs for the outlet as specified on Annex-B of MoU. As the procurement process may take time, RWB should start this process well in advance. The volume and variety of seed SPs are shown in Table above.

### 5.6.4 SP outlet operation training

RWB gives training to the staff of a SP outlet and responsible staff of a ZWO on SP outlet operation before the inauguration of the SP outlet. Training on restocking and price



revision will be provided during 1<sup>st</sup> and refreshment training should be given whenever necessary after opening the SP outlet. The outline of the training is shown in Table 5-21. Apart from the Operation Manual and Materials, various kinds of training manuals and materials are to be used in the training. The Operation Manual and Materials shown in Annex-F and G

**Table 5-21: Subject of SP operation Training**

Timing	Subjects & Necessary hours	Teaching manual & materials	Participants
<b>As of opening a SP outlet</b>	SP outlet operation <ul style="list-style-type: none"> <li>▪ process of selling SPs</li> <li>▪ recording bin cards</li> <li>▪ writing receipts</li> <li>▪ preparing monthly inventory and financial reports</li> <li>▪ conducting monthly meeting</li> </ul> (2 days: 10 – 12 hrs.)	<ul style="list-style-type: none"> <li>▪ Operation Manual, Annex-F</li> <li>▪ Operation Materials, Annex-G</li> <li>▪ Training Manual Part 1, Annex-H</li> </ul>	Staff of a SP outlet and Responsible staff of a ZWO
<b>During the 1<sup>st</sup> year</b>	Refreshment training on SP outlet operation (1 day: 6 – 7 hrs.)	Whatever necessary	Staff of a SP outlet and Responsible staff of a ZWO
	Restocking and price revision (1 day: 6 – 7 hrs.)	<ul style="list-style-type: none"> <li>▪ Operation Manual, Appendix 6</li> <li>▪ Training Manual Part 2, Appendix 8</li> <li>▪ Training Materials Part 2, Appendix 8</li> <li>▪ Training Materials Part 2 (Answer), Appendix 8</li> <li>▪ Reference for Training Part 2, Appendix 8</li> </ul>	
<b>During the 2<sup>nd</sup> year</b>	Refreshment training on SP outlet operation and Restocking and price revision (1 day: 6 – 7 hrs.)	Whatever necessary	Whoever necessary

### Promotion of a SP outlet

It is crucial to promote newly established SP outlets to WASHCOs. RWB should perform this task in collaboration with organizations which directly communicate with WASHCOs, specifically WWOs, donors, and NGOs. These organizations form WASHCOs, train them, and repair their HPs. RWB should prepare promotion tools such as leaflets and signboards, and organize meetings with WWOs and donor & NGOs as well. In the meetings, RWB can explain new SP outlets and distribute leaflets to participants, so that they can promote the outlet to WASHCOs. Since RWB does not frequently hold such meeting, a ZWO should follow up the meeting to facilitate the promotion of the SP outlets in its zone. SP outlets should effectively display a signboard and leaflet inside and outside of their outlets to let the visitors know that SPs are available. A SP outlet should start operation immediately after WWOs meeting. Figure 5-16 indicates the flow of promotion

by various stakeholders. Table 5-22 summarizes promotion activities should be taken by each stakeholder. Design of a leaflet and signboard are shown in Annex -D and F respectively.

**Figure 5-16: Flow of Promotion**

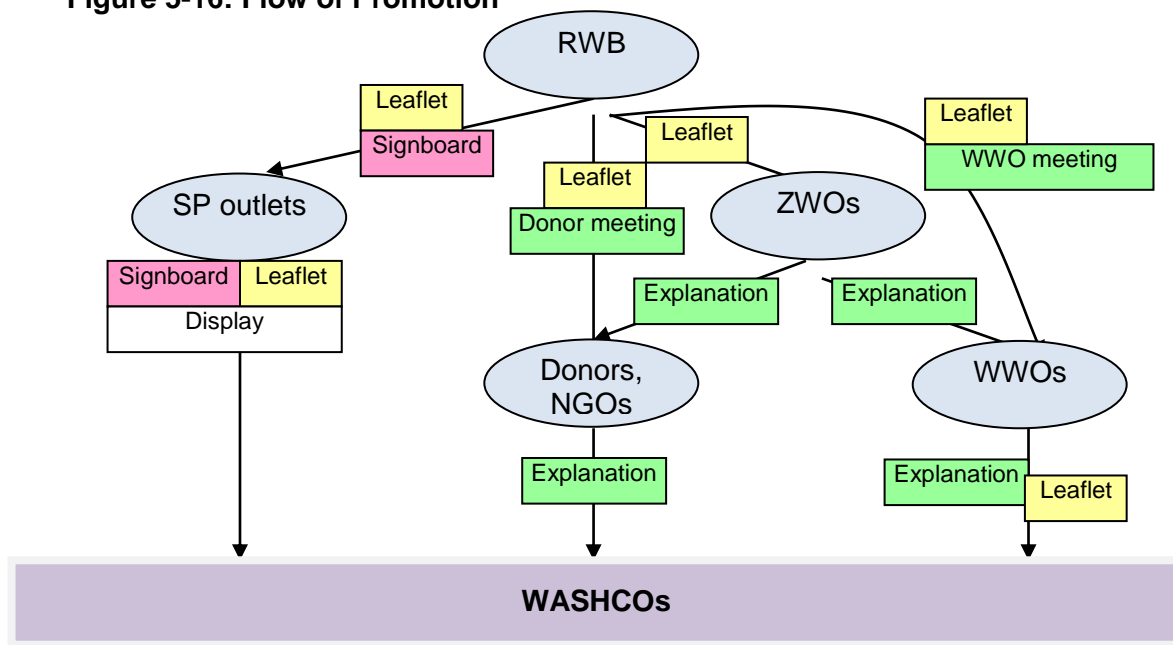

**Table 5-22: List of Actions to Promote SP Outlets**

Organizations	Actions to Promote SP outlets
<b>RWB</b>	<ul style="list-style-type: none"> <li>Prepare leaflets on SP outlets and distribute to ZWOs, WWOs, donors, and NGOs</li> </ul>
	<ul style="list-style-type: none"> <li>Prepare signboards on SP outlets and provide them to SP outlets</li> </ul>
	<ul style="list-style-type: none"> <li>Organize WWOs meeting to;               <ul style="list-style-type: none"> <li>Order to distribute leaflets to WASHCOs with proper explanations</li> <li>Order not to give free SP to WASHCOs</li> <li>Order to strengthen WASHCOs and facilitate buy SPs</li> <li>Ask for comments and opinions to improve the SP supply system</li> </ul> </li> </ul>
	<ul style="list-style-type: none"> <li>Organize donor/NGO meeting to;               <ul style="list-style-type: none"> <li>Inform new SP outlets</li> <li>Report the progress of SP supply activities</li> <li>Facilitate them not to provide free SPs</li> <li>Facilitate them to strengthen WASHCOs and buy SPs</li> <li>Facilitate them to establish SP outlets with RWBs assistance</li> </ul> </li> </ul>
<b>ZWOs</b>	<ul style="list-style-type: none"> <li>Facilitate WWOs, a SP outlet, donors, and NGOs to perform appropriate promotion activities</li> <li>Order WWOs, donors, and NGOs not to give free SPs to WASHCOs</li> </ul>
<b>WWOs</b>	<ul style="list-style-type: none"> <li>Distribute leaflets to WASHCOs with proper explanation</li> <li>Not provide free SPs</li> <li>Strengthen and facilitate WASHCOs to buy SPs</li> </ul>
<b>Donors and NGOs</b>	<ul style="list-style-type: none"> <li>Not provide free SPs</li> <li>Strengthen and facilitate WASHCOs to buy SPs from SP outlets</li> </ul>
<b>SP outlet</b>	<ul style="list-style-type: none"> <li>Effectively display leaflets inside the SP outlet and signboard outside the SP outlet</li> <li>Reproduce leaflet and distribute to expected customers</li> </ul>

## 5.7 Operation of a SP Outlet

### 5.7.1 Fundamental Objective and Major Tasks of SP Outlets

The fundamental function of SP outlets is to sell SPs at anytime. All tasks in SP outlet operation are intended to fulfil this function. There are 5 kinds of major tasks in SP outlet operation as shown in Figure 5-17, specifically (1) Open dairy, (2) Accurate record keeping, (3) Appropriate cash management, (4) Good communication, and (5) Sufficient stock at appropriate prices. These main tasks are outlined in Table 5-23. The details of SP outlet operation are given in the Operation Manual shown in Annex-F. In the operation, various formats will be used to keep records of inventory, sales, and expenditure and to calculate SPs to be restocked and new prices of SPs. The set of formants are shown as the Operation Materials in Annex-G.

**Figure 5-17: Fundamental Function and Major Tasks of SP Outlets**

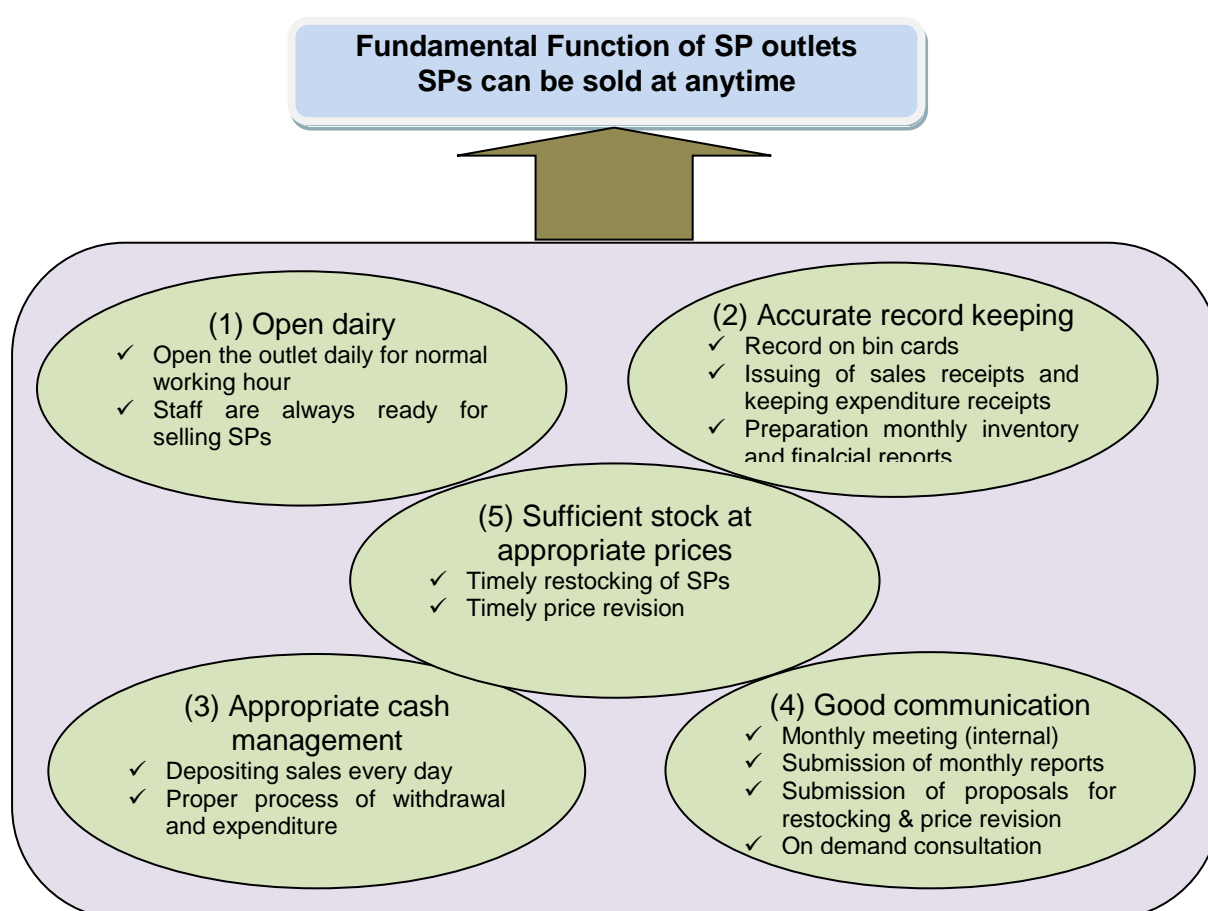

**Table 5-23: Details of Main Tasks of SP Outlet Operation**

Frequency	Tasks	Details
Daily	Selling SPs	<ul style="list-style-type: none"> <li>▪ Receiving money and depositing in a bank account</li> <li>▪ Issuing receipts and keeping their copies</li> <li>▪ Recording the change of stock on bin cards</li> </ul>
	Buying consumables	<ul style="list-style-type: none"> <li>▪ Withdrawing money</li> <li>▪ Getting and keeping a receipt</li> </ul>
Monthly	Preparation and	<ul style="list-style-type: none"> <li>▪ Preparing inventory report (source: bin cards)</li> </ul>

Frequency	Tasks	Details
	submission of reports	<ul style="list-style-type: none"> <li>▪ Preparing financial report (source: sales receipts, procurement receipts, bank statement)</li> <li>▪ Cross checking the two reports</li> <li>▪ Submitting the two reports to the ZWO</li> </ul>
	Regular meeting	<ul style="list-style-type: none"> <li>▪ Participants: Manager, accountant, storekeeper, mechanic</li> <li>▪ Agenda: stock, sales, expenditure, deposit and others</li> </ul>
<b>Yearly</b>	Inventory count (2 times / year)	<ul style="list-style-type: none"> <li>▪ Checking up inventory and bin card</li> </ul>
	Restocking (1 to 2 times / year)	<ul style="list-style-type: none"> <li>▪ Preparing restocking proposal based on remaining stock, sales, bank balance, and prices on pro-forma invoice.</li> </ul>
	Price revision (as of restocking, at least 1 time / year)	<ul style="list-style-type: none"> <li>▪ Preparing price revision proposal based on running costs, price escalation ratio, prices on pro-forma invoice.</li> </ul>

## 5.8 Supervision of SP outlets

### 5.8.1 Structure of Supervision

Water Offices including RWBs, ZWMOs, and WWOs have a responsibility to supervise all SP outlets established with the assistance of the water offices. Basically, there are two levels of supervision as shown in Figure 5-18.

First, a ZWO has a responsibility to directly supervise a SP outlet in the zone. A SP outlet should submit the monthly reports and proposals for restocking and price revision to a ZWO in the zone, and the ZWO checks the documents and request the outlet to revise if necessary. If the documents are appropriately prepared, the ZWO sends them to RWB. Moreover, if a SP outlet has a necessity to consult with water offices, the outlet should contact with a ZWO in the zone. The ZWO should not only await a consultation from the SP outlet, but also voluntary contact to the outlet to grasp the situation from time to time.

In case that a SP outlet is not located in a zonal capital, the nearest WWO has to support the ZWO to supervise the SP outlet in the zone. The monthly reports and proposals should be submitted to the ZWO through the WWO. The WWO needs to address the consultation from the outlet in collaboration with the ZWO.

Second, RWB is responsible for the SP supply chain throughout the region. RWB directly supervises concerned ZWOs and WWOs, and also indirectly supervise all SP outlets. All the monthly reports and proposals are submitted from the concerned ZWOs to RWB, and then RWB checks the documents and request the revision to the outlets through the ZWOs if necessary. If the issue of consultation by a SP outlet is beyond the capacity and responsibility of a ZWO, the ZWO have to consult with RWB. RWB should also keep contact with the ZWOs to grasp the situation of all SP outlets and ZWOs. It is recommendable for RWB to visit all SP outlets with concerned ZWOs for direct observation and consultation with them at least once a year.

**Figure 5-18: Flow of Reporting and Supervision**

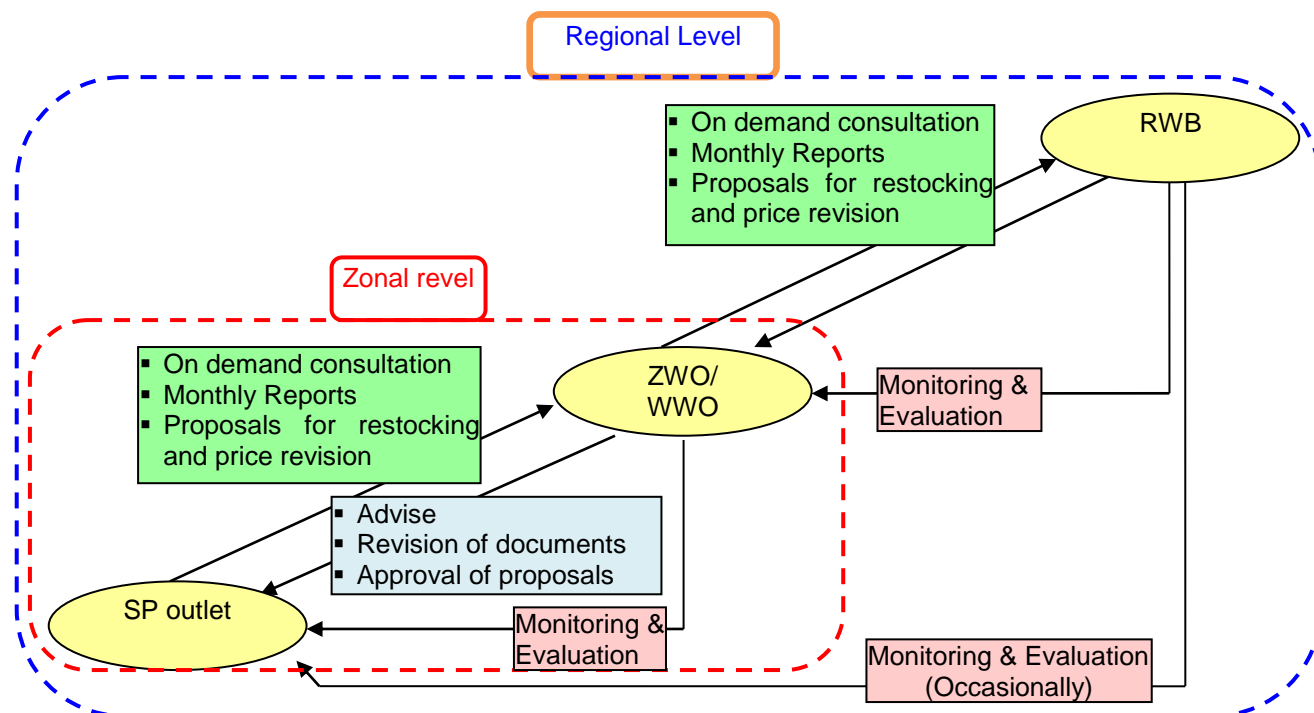

### 5.8.2 Monitoring and Evaluation

As a part of the supervision, periodical monitoring and evaluation (M & E) on SP outlets, ZWOs, and RWB should be conducted. Basically, there are two levels of M & E as shown in Figure 5-18.

First, a ZWO is primarily responsible for M & E on the SP outlet(s) in its zone. Second, RWB conducts M & E regularly on concerned ZWOs and occasionally on SP outlets in the entire region. Specifically, RWB monitors and evaluates the performance of concerned ZWOs as the direct supervisor of SP outlet(s) in their zone and also conducts M & E on SP outlets if RWB could have a chance to visit them. In addition, RWB should evaluate its SP related activities by itself. The Development Plan preparation, Monitoring and Evaluation Supportive Process of RWB is the suitable section to conduct the evaluation. The outline of the M & E is summarized in Table 5-24. Detailed evaluation items are shown in the evaluation grids for SP outlets, ZWOs and RWB prepared as annex-I.

**Table 5-24: Outline of M & E**

Evaluation target	Evaluator	Evaluation frequency	Evaluation criteria	Evaluation items
SP outlets	ZWOs (RWB and ZWO jointly evaluate 1 time/ year)	2 times/ year	Operation Capacity	Handling and recording of stock Handling and recording of sales
			Management Capacity	Open daily Monthly report submission Meeting & trouble shooting Replacement of the staff
			Sustainability Capacity	Restocking Price revision

				Dependency on others Willingness to continue
<b>ZWOs</b>	RWB	2 times/ year	Operation Capacity	Supervision of SP outlets
			Management Capacity	Routine work Trouble shooting Internal communication Replacement of the staff Direction to WWO
<b>RWB</b>	RWB	1 time/ year	Operation Capacity	Provision of training Checking monthly reports and proposals
			Management Capacity	Trouble shooting Internal communication Refreshment training Replacement of the staff M & E Promotion
			Sustainability Capacity	Continuity of existing SP outlets Planning of new SP outlets Budgeting Implementation

The evaluation results of SP outlets should be reported to RWB and also informed to each SP outlet, so that the outlet can improve its performance based on the evaluation result. With the same objective, the evaluation results of concerned ZWOs should be informed from RWB to the ZWOs. Similarly, the result of evaluation on RWB needs to be shared among the head of RWB, Water Supply and Scheme Administration Core Process owner, and staff in charge of SP issues.

### 5.8.3 Record Keeping for Supervision

In supervision by ZWOs and RWB, there are two points should be kept in mind. One is to maintain contact with the object of supervision by means of reports, proposals, and verbal communication. Another is to keep and sort out the following documents and records created and/or exchanged through the process of establishing and operating each SP outlet.

- (i) Supervision Record of Spare Parts Outlets
- (ii) MoU
- (iii) Monthly Inventory Report
- (iv) Monthly Financial Report
- (v) Proposal for Restocking
- (vi) Proposal for Price Revision
- (vii) Monitoring and Evaluation Grid
- (viii) Other necessary records

The above mentioned documents and records should be filed separately in ZWOs and RWB outlet by outlet. Advices, suggestions and directions should be given referring these records and documents. Apart from records and documents no. (ii) – (viii) which shared

with SP outlets, (i) Supervision record of Spare Parts Outlets should be prepared by ZWODs and RWB separately for the sake of supervision. On this document, information such as profile of a SP outlet, training history, consultation visit, submission of monthly reports, restocking, price revision, and any issue to be followed up are to be recorded. The sample format is shown as Annex-J.

## 5.9 Roles of various Stakeholders in Spare part Management

### 5.9.1 National Level

The Ministry of Water and Energy is committed to a Supply Chain Management system that has the upkeep of the facilities as a high priority. This means that in the budgeting process the aspects that belong to O&M are properly considered, i.e. the functions of the various government agencies in O&M (Technical Assistance, Monitoring and Supervision) need to be clearly defined (who is tasked with what assignments) and the necessary financial and human resources need to be allocated.

- Regulates the basic principles for Supply Chains and O&M
- Leaves the actual implementation steps to the various Regions (projects) and Woredas
- Minimizes conflicts caused by different O&M systems
- Provides the mandatory guidelines and the “rules of the game”
- Suggestions of what can be regulated:
  - Hand pumps and hand pump quality standards
  - Pre-qualification of Suppliers
  - Spare part subsidies, limiting or eliminating them
  - Community contribution for obtaining a hand pump

#### MoWE

- Sets policies, standards and specifications
- Appoints a specific Supply Chain Coordinator, who supervises the many various steps of the establishment of the supply chain. This “Champion” could either be a posting in the government or the job could be subcontracted to a private consultant (since it is a temporary assignment, after about 2-4 years the Supply Chain should be established and the functioning of it can be monitored by regular staff)
- Identifies the necessary financial implications of the supply chain and ensures that the arrangements comply to financial regulations
- Opens a dialogue with the private sector suppliers and the NGO’s in order to establish an atmosphere of common understanding and mutual trust
- Builds capacity at Regional and Woreda level

#### External Support Agencies

- Support MoWE in the planning of the projects and programmes and provide some technical cooperation
- Help to finance training programmes

### 5.9.2 Regional Level

- RWBs issue tenders for the supply of the annual demand of hand pumps (first time including spare parts) and invite all shortlisted, pre-qualified suppliers to participate. The tender documents for hand pumps supply specify the pumps delivered to sub-regional dealer (SRD) and do not include the price for delivery to site and installation.

- RWBs evaluate the tenders, (regions-wide, it would be advisable to split the orders between three to four suppliers, to negotiate with them an agreed price and allocate certain regions (Zones/Woredas) to the selected suppliers).
- Draw up a Hand pump and Spare Parts Supply Agreement between Regional Water Bureau, Hand Dug Well Construction/ Borehole Drilling Contractor, WASHCOs Representing Communities and Suppliers
- To support local suppliers and manufacturers the supply of equipment is pre-financed through the WASH programme (via MoFED - BoFED).

### 5.9.3 Private sector enterprises

- Participate in tenders
- Supply and install hand pumps equipment
- All hand pumps are inspected by an independent inspection agency, marked and released as ready for shipment to the SRD. The cost of the inspection has to be included in the price of the pump.
- Set up SRD, train them and supervise them in view of compliance to the rules of the game. The training of the shop owners will encompass the following topics:
  - Description of various parts of water points
  - Keeping stock
  - Maintaining cashbooks
  - General business ideas for innovative marketing
- Ensure that SRD keep the required inventory of spare parts in their stocks
- Sell hand pumps directly to NGO's civil society organizations and private customers (such hand pumps should fulfill the same QC/QA requirement but are not imported through the WASH programme)

### 5.9.4 Woreda Level

- During the mobilization phase the villages should be informed and motivated to form WASHCO's and to collect a minimum of 5% in cash. They are also informed that the hand pump will come from the appointed SRD.
- The WASHCO pays the village contribution to the WWO.
- The WWO now initiates the drilling or digging of the well.
- After completion of the well the contractor collects the hand pump directly from the SRD.
- TSPs are responsible for the overall maintenance of rural water facilities. They will be expected to provide technical support to WASHCOs whose role remains that of simple and minor repairs. Routine preventive service will be done by WASHCOs.
- The SRD notifies the TSP, who will help the contractor installing the pump. He trains the Caretaker in O&M. The WASHCO pays the TSP for installation (if so agreed)
- After this process the Contractor notifies the WWO.
- The WWO does the final quality audit. The installed pumps are inspected for compliance with standards (marking by Inspection agency)
- The finished water source is officially handed over to the WASHCO.
- The Woreda pays the SRD (or the drilling contractor) for delivery to site and installation.



## Annexes

### Annex A: Format for SP Price Calculation

Items	Phase-I				Phase-II			
	A-Woreda	B-Woreda	C-Woreda	D-Woreda	E-Woreda	F-Woreda	G-Woreda	H-Woreda
Total costs to sell and restock SPs								
Transportation costs (fuel cost) for restocking (T)								
Operation costs such as receipt, communication, photo copy, etc. (O)								
Contingency (C)								
Total costs (TC)=(T+O+C)								
Cost to be internalized into each piece of SP								
Total number of seed SPs								
Expected sales for the 1st year								
The number of SP to be sold for the 1st year (N)								
Cost to be internalized into each piece of SP (CI)=(TC/N)								

#### a) Afridev hand pump SPs

Target Region			Region - X			
Target Area			X-Zone in the region	Y-Zone in the region	Z-Zone in the region	T-Zone in the region
No.	SP Name	Purchasing Price (Birr)	Unit Price (Birr)			
1	O - Ring					
2	U - Seal					
3	Bobbin					
4	Plunger					
5	Foot Valve					
6	Bush Bearing					
7	Rod Centralizer					
8	Fulcrum Pin					
9	Cylinder Assembly					
10	PVC Pipes					
11	Coupling for PVC pipes					
12	Rod					
13	Rod Hanger Pin					

**Community Based Operation and Maintenance Management Manual for Rural Point Water Supply Schemes**

14	Nylon Rope					
15	Cement Solvent					
16	Solvent Cleaner					
17	PVC pipe Centralizer					

**b) Indian Mark - II hand pump SPs**

Target Region			Region - X			
Target Area			X-Zone in the region	Y-Zone in the region	Z-Zone in the region	T-Zone in the region
No.	SP Name	Purchasing Price (Birr)	Unit Price (Birr)			
1	Chain					
2	Piston					
3	Bearing					
4	Cylinder					
5	Rubber Sealing					
6	Socket (coupling)					
7	Sealing Ring					
8	Upper Foot Valve					
9	Head Bolt and Check Nut					
10	GI Pipes					
11	Road					
12	Cup Seal					

## Annex B: Sample of MoU (in case of X zone)

**The Memorandum of Understanding between the Regional Water Bureau, XX- Zonal Water Office, and YYY Town Water Supply in  
----- Regional State in the Federal Democratic Republic of Ethiopia,**

The document attached hereto constitutes an agreement between the parties consisting of the Regional Water Bureau in ----- Regional State in the Federal Democratic Republic of Ethiopia (hereinafter referred to as “the RWB”), XX Zonal Water Office in ----- Regional State in the Federal Democratic Republic of Ethiopia (hereinafter referred to as “the ZWO”), and YYY Town Water Supply in ----- Regional State in the Federal Democratic Republic of Ethiopia (hereinafter referred to as “the TWS”).

(Insert regional Capital), August, 2013

\_\_\_\_\_  
Mr. XXXXXX XXXXXXXX  
Head  
The Regional Water Bureau

\_\_\_\_\_  
Regional State

\_\_\_\_\_  
Mr. XXXXXX XXXXXXXX  
Head  
YYY Town Water Supply

\_\_\_\_\_  
Regional State

\_\_\_\_\_  
Mr. XXXXXXXX XXXXXXXX  
Head  
XX Zonal Water Office

\_\_\_\_\_  
Regional State



## The Attached Document

**I. Purpose**

The purpose of the agreement is to supply the spare parts of hand pumps<sub>1</sub> (hereinafter referred to as SP”) at the SP outlet which is to be operated by the TWS in collaboration with the RWB, the ZWO, and Woreda Water Offices in XX zone (hereinafter referred to as “the WWOs”).

**II. Spare Parts Supply System**

Under this agreement, SPs become available in the SP outlet at reasonable prices sustainably. Initially, a set of the spare parts are provided to the TWS by the RWB. The SPs are sold at the SP outlet in the TWS at prices calculated based on the market prices of the SPs, transportation costs, and handling charge. The SP outlet keeps the sales for restocking so that SPs are supplied sustainably. The concept of the above mentioned spare parts supply system is shown in Appendix I. In order to establish the system and make it functional sustainably, the RWB, the ZWO, the SP outlet, and WWEOs fulfill their responsibility stipulated in section IV. Responsibilities of the Parties.

**III. Target Area and Target Customers**

The target area of the spare parts supply system is the entire XX zone. Primary target customers are water, sanitation, and hygiene committees (WASHCOs) in the target area. However, SPs will be sold to customers from outside the area and non-targeted customers such as NGOs.

**IV. Period of Agreement**

This agreement becomes effective when this document is signed by the Parties, and will expire in (Insert month and year).

**V. Responsibilities of the Parties****1. The RWB**

The RWB agrees to perform the following activities and provide the following resources.

- (1) Provide seed SPs to an SP outlet as specified on MoU (in case the SP outlet will be established applying the seed SP provision model).
- (2) Determine the price of SPs
- (3) Provide the staff of the SP outlet with necessary knowledge and skills to operate its outlet
- (4) Obtain monthly inventory and financial reports from the ZWO, check them, and order revision if necessary to the SP outlet through the ZWO
- (5) Check, order revision if necessary, and approve a restocking proposal in consultation with the ZWO
- (6) Check, order revision and approve a price revision proposal in consultation with the ZWO
- (7) Provide the SP outlet, the ZWO, and the WWOs with technical and administrative advises and directions
- (8) Prepare leaflets and sign board to promote the SP outlet

- (9) Promote the SP outlet to WASHCOs outside the target area through relevant ZWOs and WWOs
- (10) Assist and facilitate ZWOs and WWOs to reorganize and/or strengthen WASHCOs and not to provide free SPs
- (11) Supervise the spare parts supply system in this region

## **2. The ZWO**

The ZWO agrees to perform the following activities.

- (1) Obtain monthly inventory and financial reports from the SP outlet, check them, order revision if necessary, and send them to RWB
- (2) Advise and facilitate the SP outlet to prepare the proposals of restocking and price revision when necessary
- (3) Check, order revision if necessary, and approve a restocking proposal in consultation with RWB
- (4) Check, order revision and approve a price revision proposal in consultation with RWB
- (5) Inform the revised prices of SPs to WASHCOs in the target area through the WWOs
- (6) Promote the SP outlet to WASHCOs in the target area through the WWOs.
- (7) Assist and facilitate WWOs to reorganize and/or strengthen WASHCOs and not to provide free SPs
- (8) Supervise the spare parts supply system in the target area

## **3. The SP outlet**

The SP outlet agrees to perform the following activities.

- (1) Prepare initial stock of SPs as specified on MOU (in case the SP outlet will be established applying the no-seed SP model)
- (2) Open a new bank account to manage the sales of SPs
- (3) Revise the performance evaluation sheet of each staff to include the tasks for SP outlet MoU – 3 operation (in case a SP outlet is operated by water offices or TWS)
- (4) Store and sell SPs
- (5) Record sales, expenditure, and stock of SPs
- (6) Prepare monthly inventory and financial reports and revise them according to the comments from the ZWO and RWB
- (7) Conduct monthly meeting among the staff
- (8) Restock SPs with the approval of the ZWO and RWB
- (9) Revise the price of SPs with the approval of the ZWO and RWB
- (10) Consult with the ZWO whenever necessary

## **VI. Modification**

The contents of this document may be amended at any time by a written agreement by the Parties.

## **VII. Dissolution of Agreement**

The agreement may be dissolved if (i) the SP outlet does not fulfill its responsibilities stipulated on this document, or (ii) the Parties agree it. Once the dissolution is decided and notified to the SP outlet, the supplier must return all sales from the initial stock of the spare parts and the remaining stock or pay xxxxxx.00 (insert amount in word) Birr to the RWB immediately.

### Annex C: Basic Concept of the Spare Parts Supply System

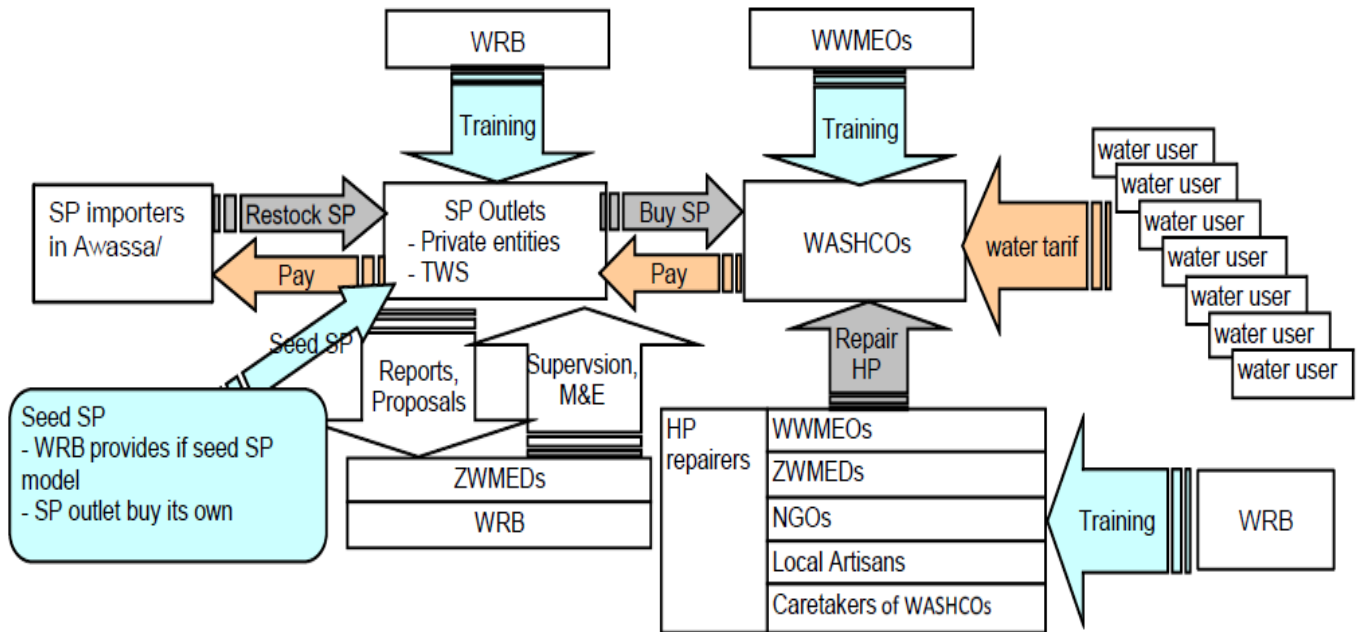

Annex D: Sample of a Sign Board

# አፍሪዴቭ የእጅ የውሀ ፓምፕ ከነመለዋወጫዎቹ



Sign board - 1

**Annex E: Spare Part Supply System**

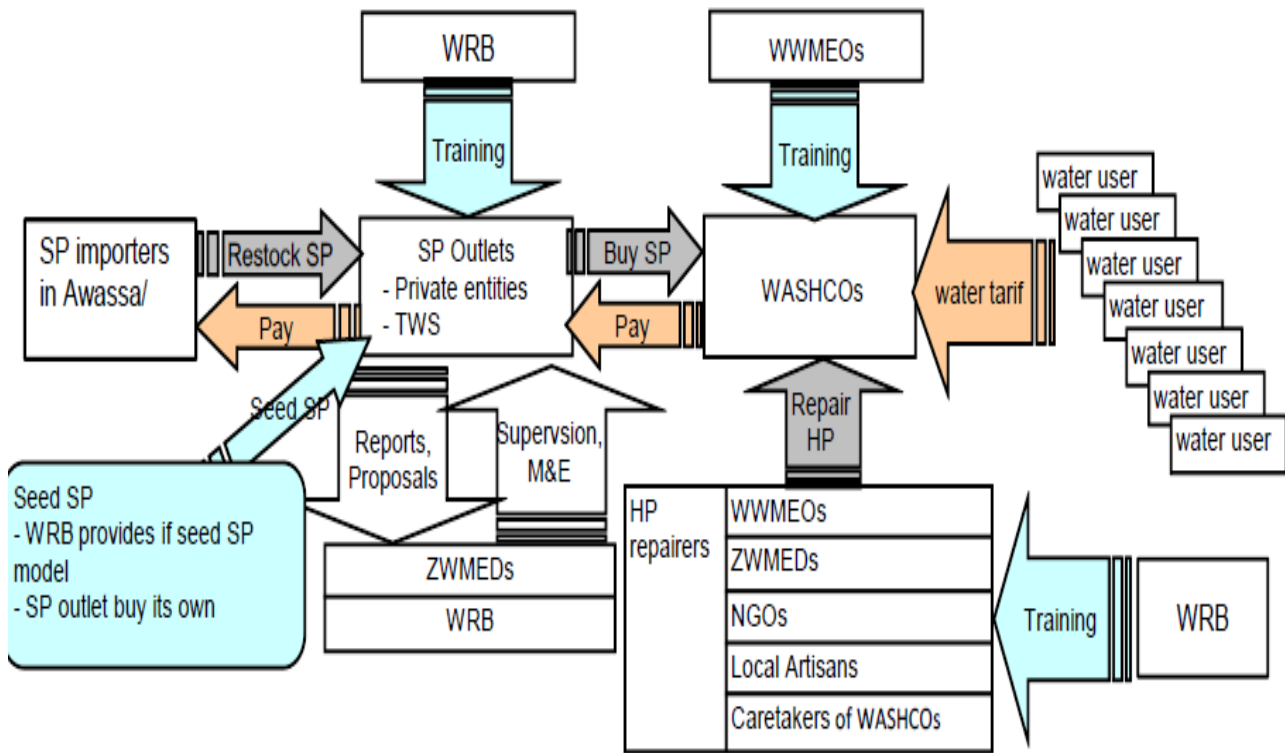



**Community Based Operation and Maintenance Management Manual for Rural Point Water Supply Schemes**

**Annex F: Monthly Financial Report (This sheet must be submitted every month.)**

Month and year \_\_\_\_\_

Date	Categories (Afridev / India Mk II / Rope pump / Others1)	Items	Sales			Expenditures			Balance
			Unit price	Quantity	Total	Unit price	Quantity	Total	
Friday									
Last Day									

**Prepared and Submitted by:**

**Organization**

**Title/Position**

**Name**

**Sign**

**Date**



**Community Based Operation and Maintenance Management Manual for Rural Point Water Supply Schemes**

**Annex G: Proposal for Restocking**

No.	Name of Spare Parts	(1) Initial volume of stock <sup>2</sup>	(2) Existing volume of stock	(3) Volume of sales (1)-(2)	(4) Period in months to sell the volume <sup>3</sup>	(5) Ideal volume of stock =(3)x12 /-4	(6) proposed quantity to be restocked =(5) - (2)	(7) Finalized quantities to be restocked based on 5 - 2	(8) Volume of stock after restocking (2)+(7)	(9) Comments by ZWO
<b>A</b>	<b>Afidev</b>									
1	O - Ring									
2	U - Seal									
3	Bobbin									
4	Plunger									
5	Foot Valve									
6	Bush Bearing									
7	Rod Centralizer									
8	Fulcrum Pin									
9	Cylinder Assembly									
10	PVC Pipes									
11	Coupling for PVC pipes									
12	Rod									
13	Rod Hanger Pin									
14	Nylon Rope									
15	Cement Solvent									
16	Solvent Cleaner									
17	PVC pipe Centralizer									
<b>B</b>	<b>Indian Mark-II</b>									
1	Chain									
2	Piston									
3	Bearing									
4	Cylinder									
5	Rubber Sealing									
6	Socket (coupling)									
7	Sealing Ring									
8	Upper Foot Valve									
9	Head Bolt and Check Nut									
10	GI Pipes									
11	Road									
12	Cup Seal									
<b>C</b>	<b>Rope Pump</b>									
	Nylon rope (m)									
	Piston d 1inch									
	Piston d 3/4inch									
	Piston d 1/2 inch									
	PVC pipe d 1inch /m									
	PVC pipe d 3/4inch / m									
	PVC pipe d 1/2 inch / m									
<b>D</b>	<b>Others</b>									

Prepared and Submitted by:	
Organization	
Title/Position	
Name	
Sign	
Date	



**Community Based Operation and Maintenance Management Manual for Rural  
Point Water Supply Schemes**

---

